

DN MULTI-TASKING MACHINING TURNING CENTER

DNX 2100

- DNX 2100** Essential
- DNX 2100** Performance
- DNX 2100** Advanced

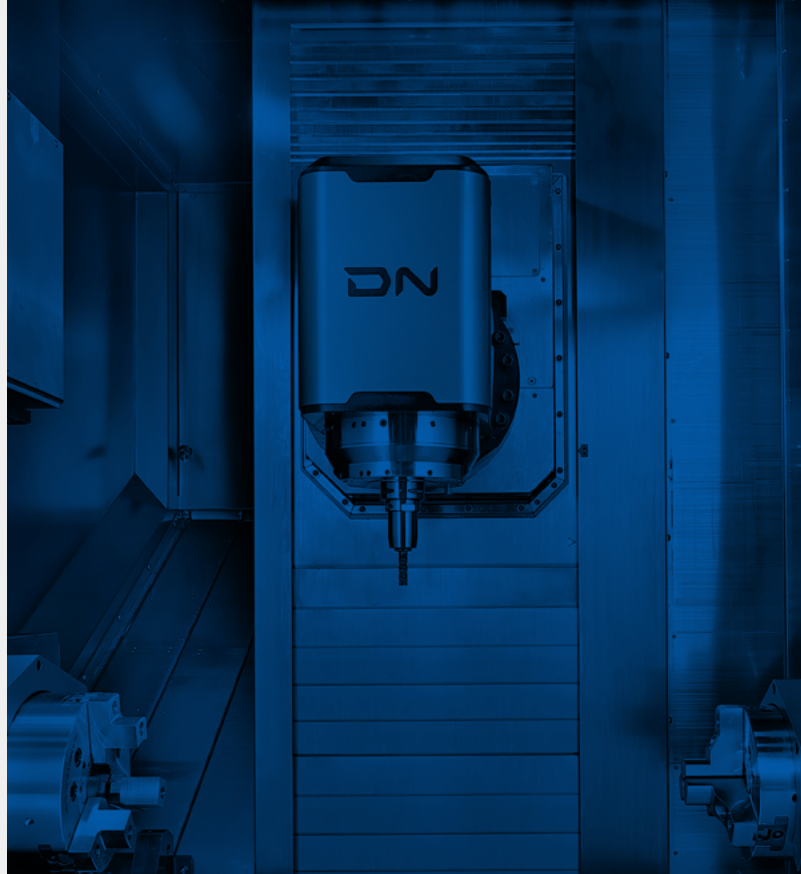

DNX series

The DNX Series is our multi-tasking solution, offering exceptional productivity, precision machining performance, and innovative ease of operation. Using a single machine, multiple processes can be seamlessly integrated to maximize productivity while minimizing operation time and labor consumption.

Compared to other machines in its class, the DNX Series delivers top-tier machining performance.

With industry-leading thermal displacement minimization technology and an ultra-precise control system, the DNX Series excels in high-precision tasks. Additionally, the DNX Series features user-centered ergonomic design to maximize operational convenience, and presents an innovative solution optimized for next-generation manufacturing environments.

Precision. Efficiency. Innovation. DNX is setting a new standard in multi-tasking machining technology.

CONTENTS

Product Overview

Basic Information

- 06 Basic Structure
- 07 Machining Area
- 08 Spindle
- 09 Cooling & Thermal Compensation Concept
- 10 Application Performance
- 11 Option Package
- 12 Automatic Tool Changer
- 13 Ergonomic Design
- 14 ROBOSOL | In-factory automation
- 15 COBOSOL

Detailed Information

- 16 FANUC Oi PLUS
- 18 Siemens S-ONE
- 19 Standard / Optional Specifications
- 20 Peripheral Equipment
- 21 DNX Global 3 Package
- 22 Power | Torque
- 23 External Dimensions
- 24 Working Range
- 25 Machine Specifications

Customer Support Service

- 26 Why DN Solutions
- 27 Customer Support and Services
- 27 Global Network



**SUPER-STRONG
MULTI-TASKING MACHINING
PERFORMANCE,
NEXT-LEVEL PRODUCTIVITY**



- Multi-tasking machining with main/sub spindle and B-axis milling, which enables perfect machining with one-time setting.
- Securing outstanding stability and durability with a next-generation machine frame that applies high-strength structural analysis.
- Expanded processing range and optimized multiple tasks using an orthogonal Y-axis structure.

**PERFECT MACHINING
QUALITY,
PRECISION CONTROL
TECHNOLOGY**



- Effectively minimizing spindle thermal displacement by applying a spindle oil cooling device.
- Guaranteeing the best precision even in micro-machining with ultra-precision B-axis 0.0001° control and C-axis 0.001° control functions.

**ERGONOMIC DESIGN,
INTUITIVE OPERATION**



- Maximized operational convenience with user-oriented innovative design and optimal work movement line.
- Quick and easy tool change with an intuitive interface, by applying a dedicated touch screen ATC system.
- Reduced maintenance and setup time by accessing the tool magazine and main operation units quickly and easily, based on optimized accessibility design.



DNX series

Tool breakage detector

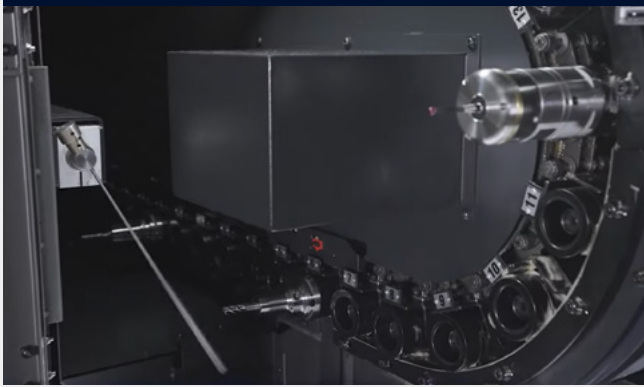

Max. tool storage

30 {60 OPTION} tools

Built in

Diameters up to

8{10} inch **81** mm (3.2)

Various workpieces can be machined from bar stock with diameters of up to 81 mm, allowing for faster and more efficient operation without the need for jaw machining jigs.

Steady rest



Part catcher



A built-in part catcher that does not interfere with the machining area. The protrusion distance can be adjusted from the operation panel using servo drive.

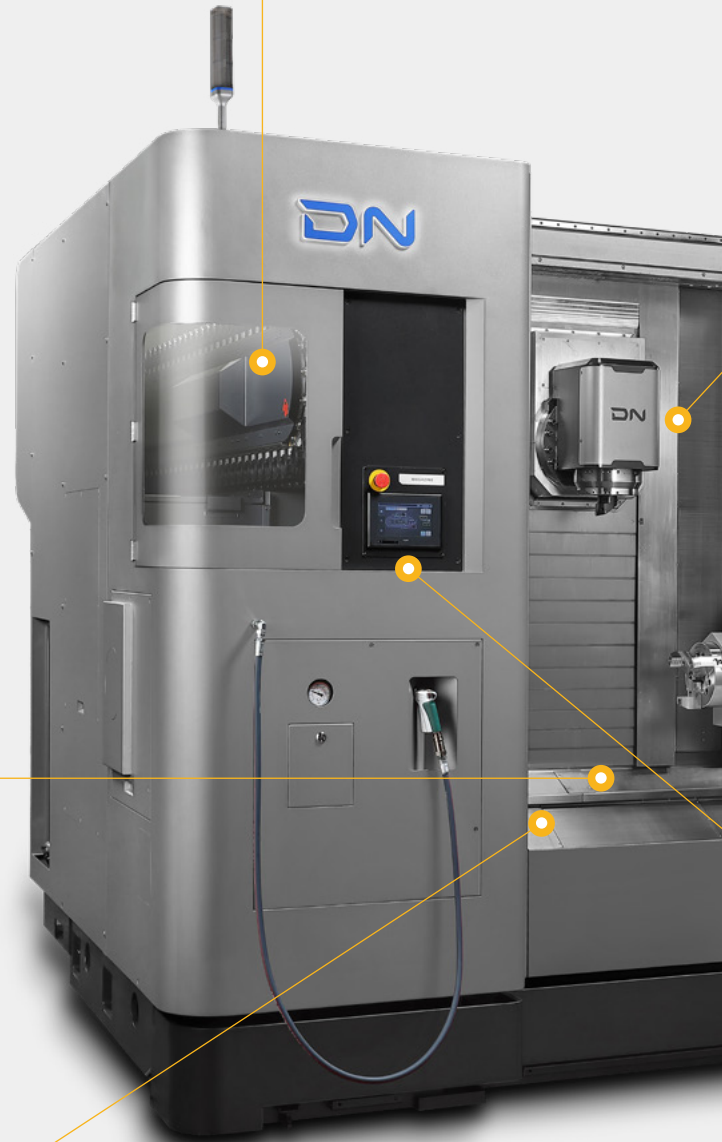

Milling spindle

12000 r/min

Excellent structural rigidity is provided by arranging high-rigidity bearings, and high rigidity clamping structure is applied to provide stable cutting performance even under heavy-duty machining conditions.

Milling spindle taper

HSK-T63(A63) {CAPTO C6}

B-axis

0.0001°

The B-axis supports high-precision segmentation of 0.0001° and high clamping torque, ensuring stable performance even in heavy-duty cutting conditions, and minimizes thermal displacement by separating the servo motor from the mechanical structure.

Sub spindle

8 inch



Servo driven tailstock drilling function

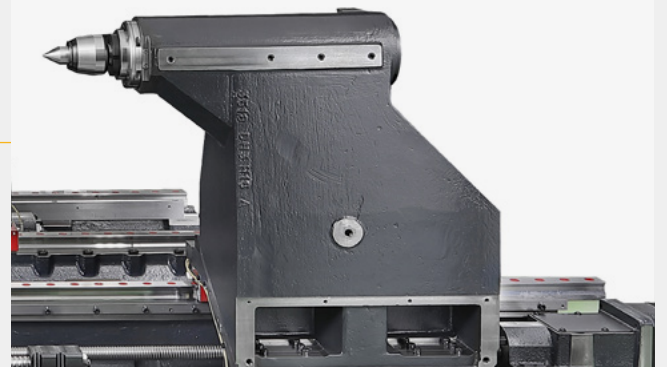

(w/Ball screw, Live center)

Touchscreen on the 7-inch Magazine operation panel



A 7-inch touch panel is installed as standard, enabling intuitive monitoring of the magazine status.

FANUC 0i



Siemens S-ONE



BASIC STRUCTURE

Mounted vertically onto the optimally designed main frame, the structure features a symmetrical design to enhance structural stability and compensate for thermal displacement. As a result, high rigidity and damping characteristics can be secured, which maximizes both static and dynamic stability of the entire system and maintain ultra-precision tolerances, by effectively controlling micro-vibrations even in high-speed turning and multi-tasking environments.

High rigidity design structure

Application of high rigidity bed structure and optimized support system

Improved overall rigidity by applying the X-rib structure, and increased structural stability by arranging the level blocks in the optimal position.

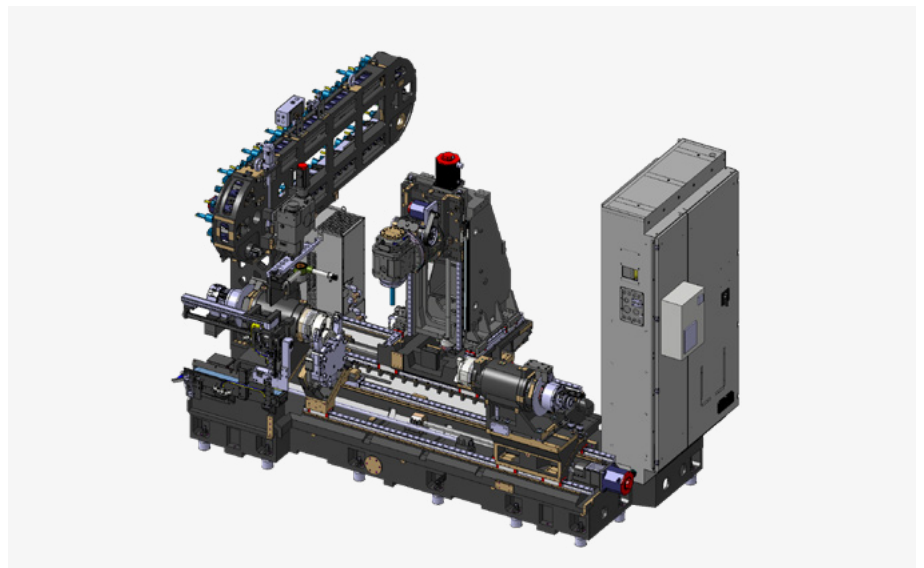
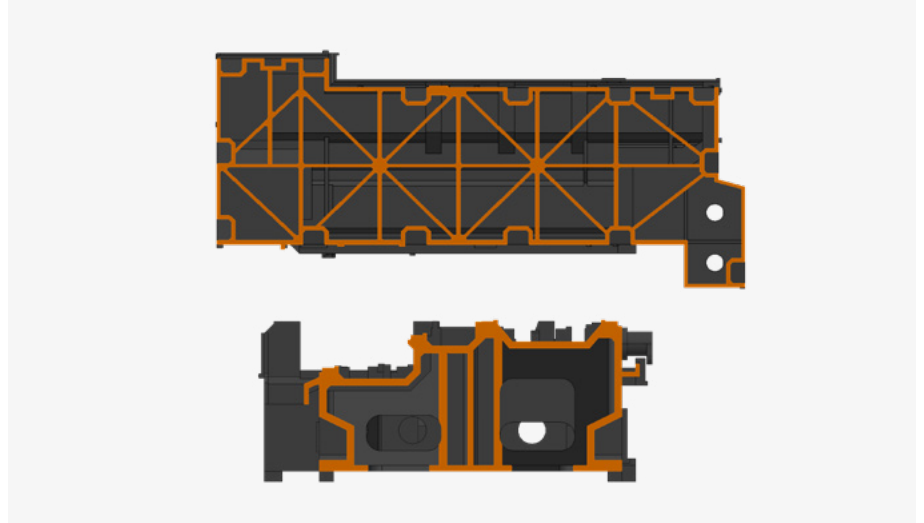

Upgraded feed system

Structural design considering stability and precision

Enhanced physical stability of the machine by expanding the span width of the X, Y, and Z-axis and minimizing the protrusion distance of the milling spindle. Also enhanced positioning precision by applying a linear scale to the X-axis as standard. Moreover, the travel distance of the Y-axis is expanded to the highest level in its class.

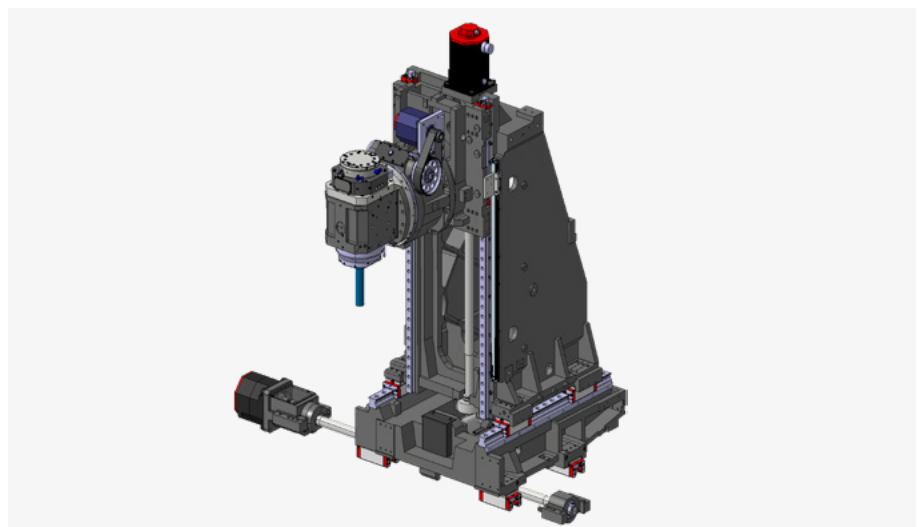

MACHINING AREA

Minimized interference between each axis while minimizing the structural stability and vibration suppression performance of the entire machine by applying a high-rigidity orthogonal structure, which maintains excellent precision and repeatability even in high-speed machining and heavy-duty cutting environments, and enables handling parts of various shapes with a single machine by securing an optimized machining stroke and maximum working area compared to other machines of the same class.

Maximized X-axis and Y-axis machining areas with orthogonal structural design

Parts of various sizes and shapes can be machined with a wide X-axis and Y-axis machining area, which also makes machining programming and setup easier.

X-axis machining area

760 mm (29.9 inch)
(-20/+740mm (-0.8/+29.1 inch))

Y-axis machining area

230 mm (9.1 inch) ($\pm 115\text{mm}(\pm 4.5)$)

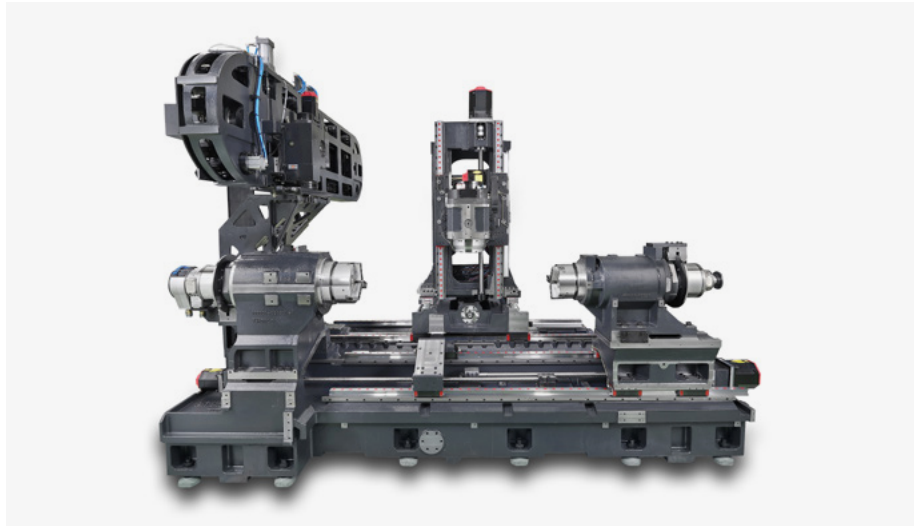

Expanded machining area

Large and long workpieces can be machined thanks to the expanded machining area, and easy access to the interior with working area when loading and unloading workpieces thanks to the improved spindle access distance.

Max. machining diameter (A/B)

520 / 410 mm (20.5/16.1 inch)

Max. machining length (C)

1100 mm (43.3 inch)

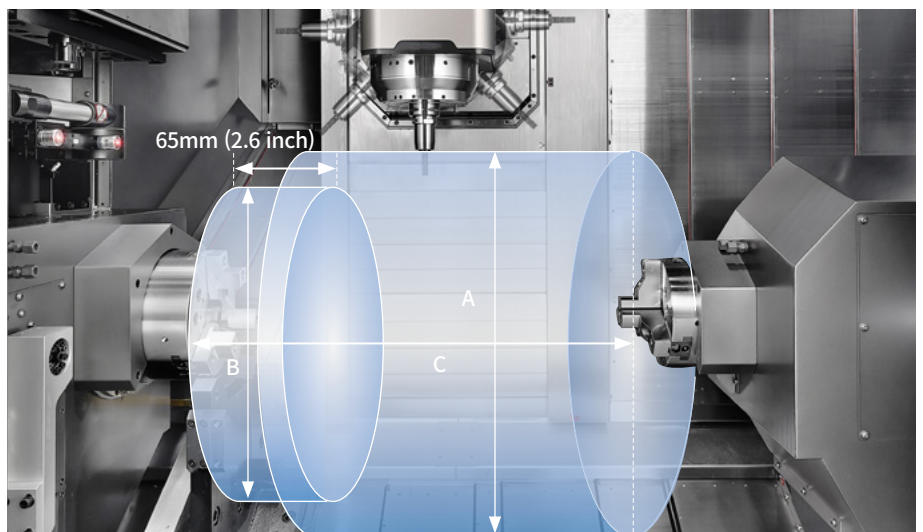

Wide bar machining diameter

Bar workpiece up to 81 mm in diameter can be loaded.

DNX 2100/S

67 mm (2.6 inch)

DNX 2100B/SB

81 mm (3.2 inch)

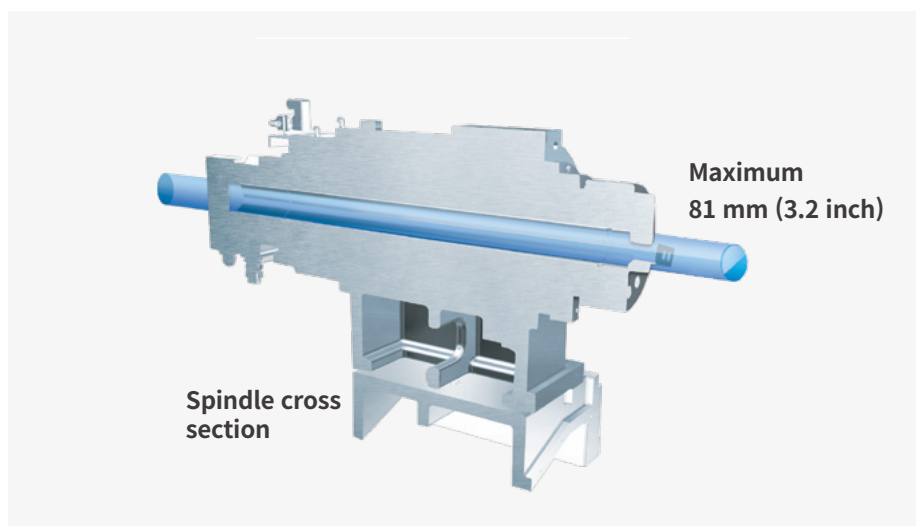

SPINDLE

The high-performance spindle that flexibly handles various workpieces, which is designed to efficiently provide high-power and high-torque performance using a single machine. This combination maintains stable cutting power even in complex processes and dramatically improves machine precision and work stability.

Milling spindle

12000 r/min

FUJIAN	SIEMENS
18.5 kW	14.9 kW
(24.8 Hp)	(20.0 Hp)

Tool type

HSK-T63(A63)*

{CAPTO C6} *HSK-T63 and A63 specification tools are compatible.

Left spindle

DNX 2100/S

8 inch

DNX 2100B/SB

10 inch

Right spindle

DNX 2100S/SB

8 inch



High-precision position control of the C-axis and B-axis (Spindle rotation axes)

Equipped with a powerful milling spindle, the DNX series enables high-precision B-axis positioning, allowing for drilling, tapping, and end milling at any angle or slope.



B-axis 240° (±120°) Large B-axis Stroke

C-axis position control capability



High-precision C-axis position control of the spindle

A position control compensation sensor is applied to the left spindle to improve the rotational position precision of the C-axis. Therefore, the C-axis can control the angular position within 0.001 degrees at a 360-degree rotation angle.

B-axis rotation angle and position control of the milling spindle

The milling spindle can control the angle of the B-axis up to 240 degrees (±120 degrees) with a precision of 0.0001 degrees, enabling perfect machining - both face machining and complex shape machining with various high-precision slopes.

Arbitrary angle machining

In the entire rotation section of 240 degrees (±120 degrees), the B-axis maintains stable performance even during heavy-duty cutting operations with strong holding power at any angle.

Tail stock

The servo tailstock, which can be set up easily and quickly, maximizes production efficiency at the machining workplace.

Servo-driven Tailstock

The servo tailstock, driven by a servo motor and ball screws, enables faster and easier machining setup, since it is driven by the CNC program without manual intervention by the operator. This setup enhances production efficiency by minimizing both operator setup time and non-cutting time during machining.

Model	Tailstock travel mm (inch)	Max. quill thrust force kN	Tailstock center
DNX 2100	1160 (45.7)	7	Live center #5 {Built-in dead center #4}

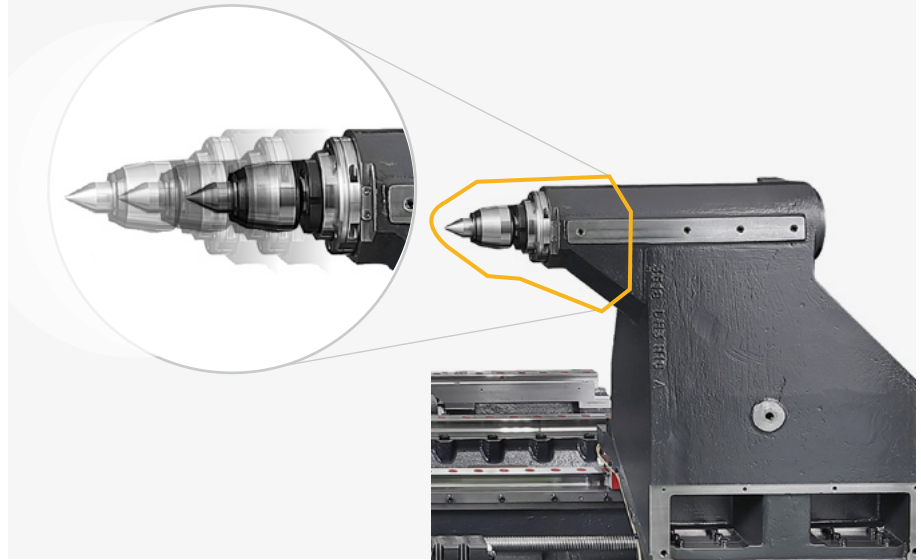

COOLING & THERMAL COMPENSATION CONCEPT

A high-rigidity bed design and precision cooling system are applied to suppress structural thermal deformation, minimizing local expansion and frame distortion caused by major heat sources. As a result, the machine maintains consistent machining quality and high positional accuracy, even during extended continuous operations and high-speed cutting environments, preventing loss of precision

Minimized thermal displacement with oil cooling

The spindle cooling device minimizes thermal displacement that occurs during long-hour machining, and further improves positioning accuracy.

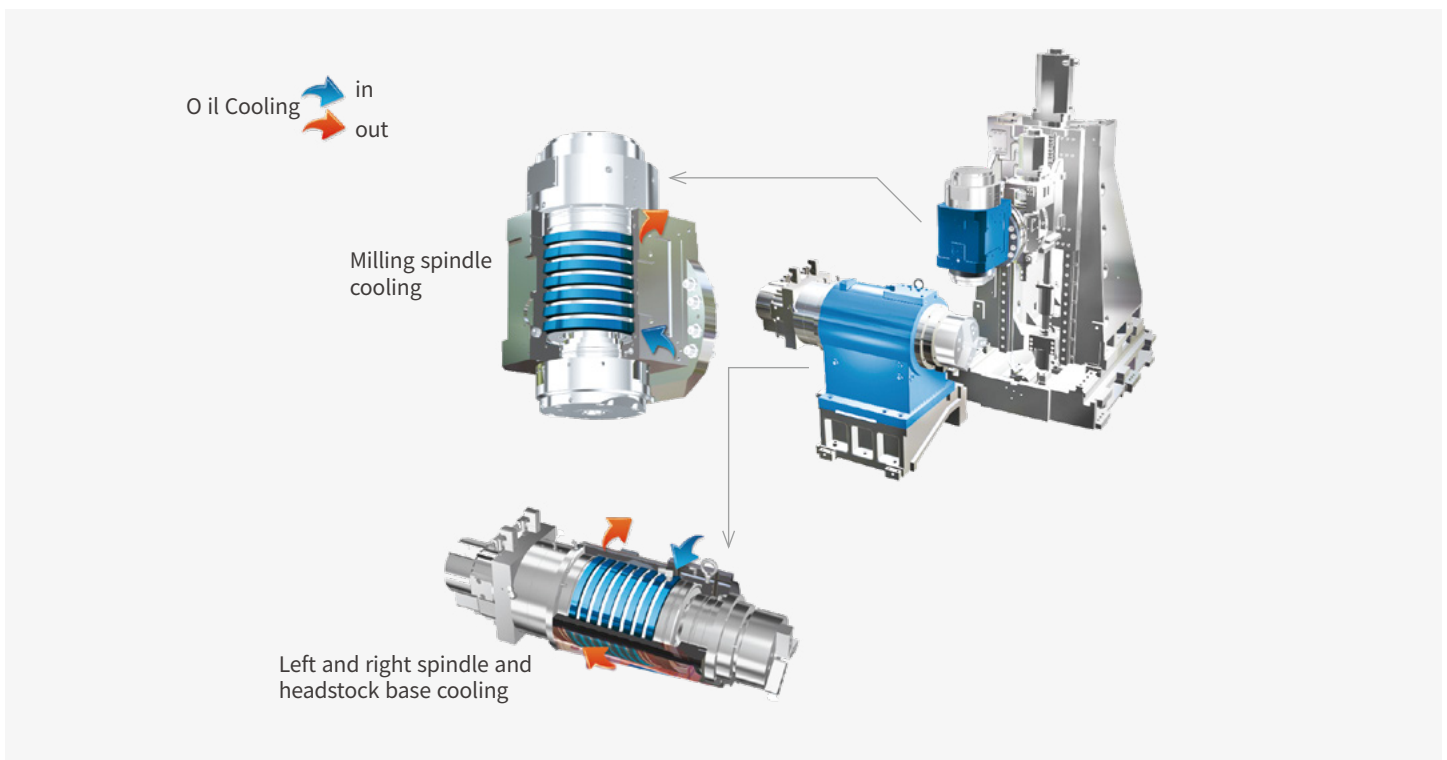

APPLICATION PERFORMANCE

The multi-tasking capabilities of the left and right spindles, B-axis, and milling function deliver productivity comparable to three conventional machines—all within a single setup.

Benefits of the multi-tasking machine

Work that used to require 2-3 or more machines can now be performed with just one machine and one-time setup. As a result, it reduces work costs by minimizing time and manpower and shortens non-machining time by 75%, making it advantageous for small quantity batch production.

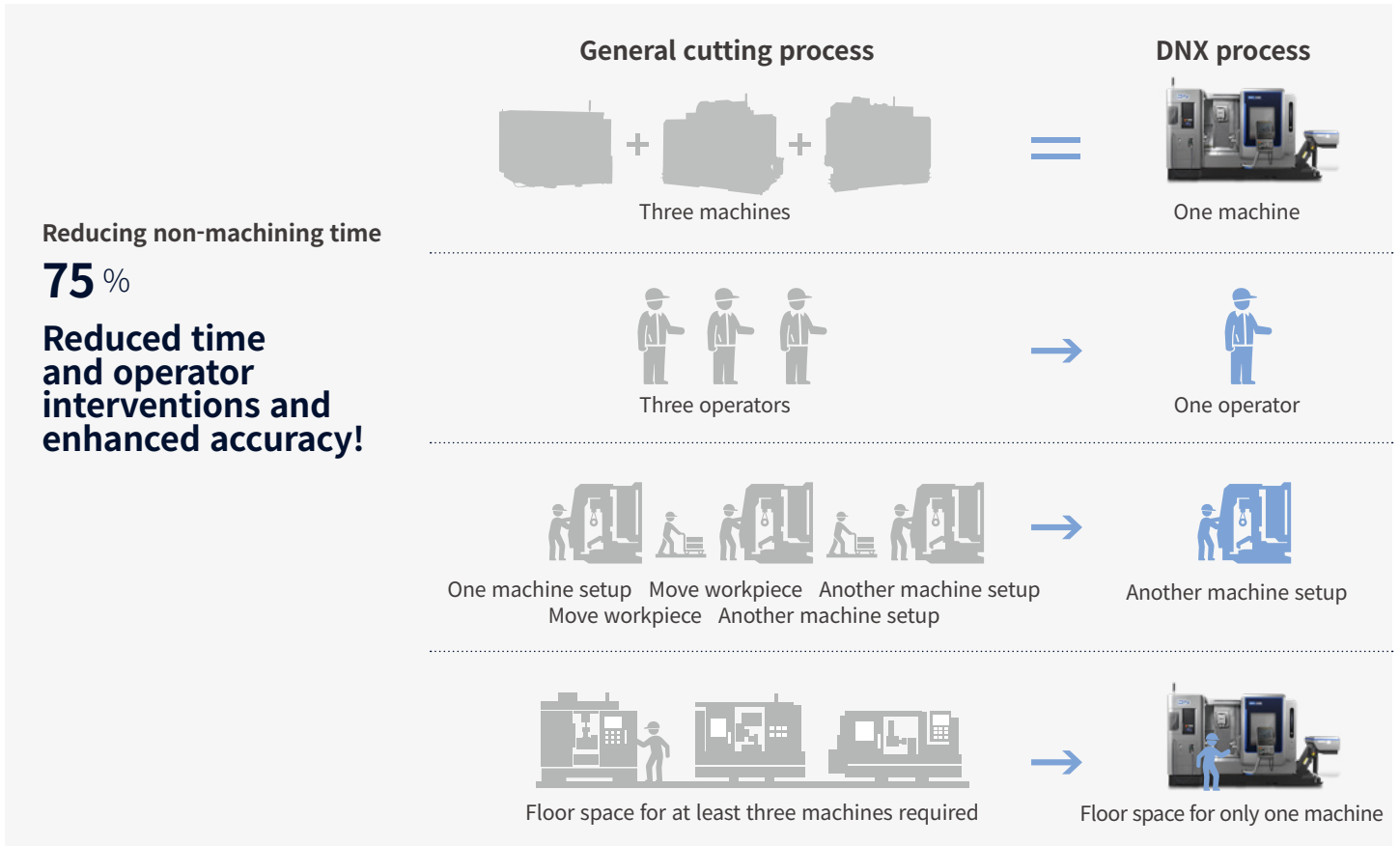

Various machining functions of the multi-tasking machine

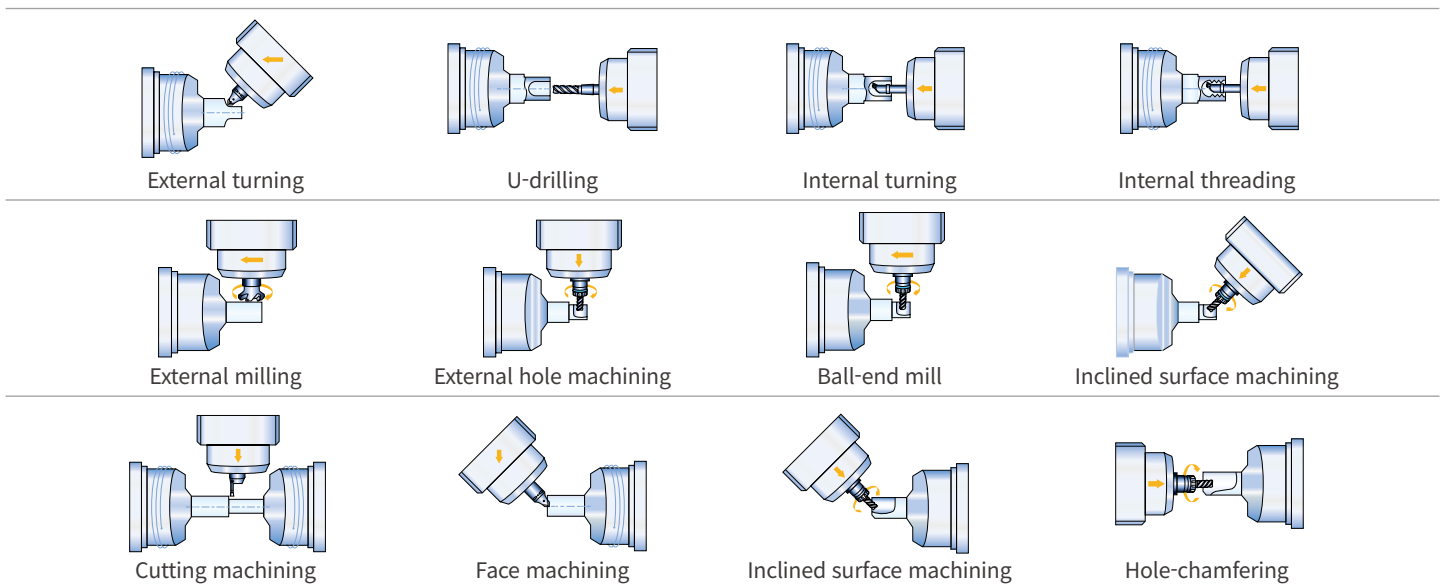

AUTOMATIC TOOL CHANGER

The high-performance automatic tool changer, equipped with a servo-controlled arm, enables fast and precise tool changes. The tool changer can store up to 60 tools, providing flexibility for a wide range of machining processes. Its robust structure supports tools weighing up to 8 kg, ensuring stable operation even with heavy tools. High-speed, high-precision design and modular structure ensure production efficiency and facility expandability at the same time.

Servo tool changer and tool magazine

The tool magazine can hold up to 60 tools and provides excellent work efficiency, since the desired tool can be mounted immediately regardless of the tool order.

Max. tool storage

30 {60 OPTION} tools

Max. tool length (from gauge line)

300 mm
(11.8 inch)

Max. tool weight

8 kg
(17.6 lb)

Max. tool diameter (if there is a nearby tool)

78 mm
(3.1 inch)

Max. tool diameter (If there is no nearby tool)

125 mm
(4.9 inch)

Operation panel touch screen

7 inch



Easy tool inspection and maintenance as the machine is located at the front of the machine.

ATC operation panel

The status of the ATC and tool magazine unit can be visually monitored, as the graphic touch panel display and touch operation are applied. The ATC, tool magazine, and tool feed pot can be operated separately using the touch screen.



ATC-magazine information display

The current condition and operating status of the ATC magazine, which is otherwise difficult to monitor in person, can be easily viewed at a glance on the large 7-inch screen.

Touch operation and manual operation

Only the buttons corresponding to functions that can be used in the current state are displayed. The operator can perform complex manual operations easily by touching individual or continuous action buttons.

ERGONOMIC DESIGN

Ergonomic design ensures easy access to the spindle, allowing operators to perform setup and maintenance in a more comfortable posture. Designed for easy identification and access to major parts and inspection points, this improves both work efficiency and safety. It not only shortens setup time but also reduces operator fatigue, helping maintain high work quality during extended shifts.

Convenience of maintenance with ergonomic design

User convenience is enhanced by strategically positioning the tool magazine and operation panel key components used during tool and workpiece setup for easy access, along with providing straightforward operation methods.



1 Left/right rotatable control panel

- Full rotation of the operation panel (including hinge structure): 0 to 120 degrees
- Controller rotation: 0 to 90 degrees

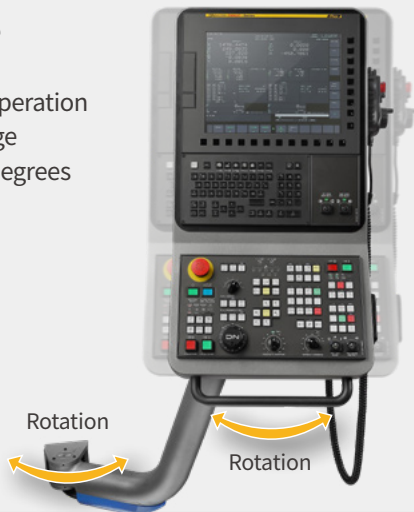

2 Convenient front placement of the tool magazine, ATC-magazine operation panel

Easy tool loading, management and monitoring using the touch screen



3 Easy spindle access structure

Increased spindle accessibility for quick and easy setup and maintenance

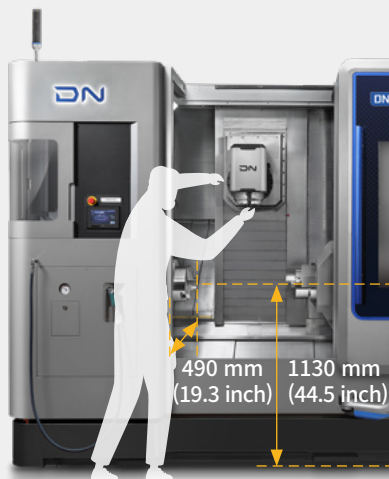

4 Enlarged front window

Operators can monitor the work progress with a wide field of view through a large window.



OPTION PACKAGE

Frequently selected options are packaged separately by function. Functions can be selected quickly and intuitively without selecting separate specifications.

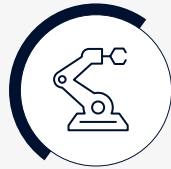

Measuring package

RMP60QE +
RMIQE(Receiver) +
HPMA(Tool Setter)

Measuring package pro

RMP60QE +
RMIQE(Receiver) +
HPMA(Tool setter) +
NC4(Laser Tool setter)

Automation interface package

Automatic Door,
Robot interface
Profinet

Barfeeder interface package

Bar Feeder interface,
Parts Catcher with
belt, Workpiece
ejector TSC

Steady rest package

Steady rest,
quick -change
system, SLU 3.1

STEADY REST

The steady rest is an essential auxiliary device that stabilizes long workpieces during machining, preventing vibration and enabling highly precise operations. Equipped with an automatic clamping mechanism and vertical structure, it enhances work efficiency while reducing vibration, leading to extended tool life and improved machining quality. It provides a solution optimized for high-precision continuous machining by providing stable support even at high rotational speeds.

Providing world-best tailstock and sub-spindle accessibility

The addition of the K3 steady rest parking function with an 8" chuck ensures world's best approach distances for between the tailstock and sub-spindle, even with the steady rest mounted. Additionally, it significantly improves user convenience through the feed axis with independent control of the servo motor, the quick-change steady rest option, and the steady rest structure design parallel to the X-axis.

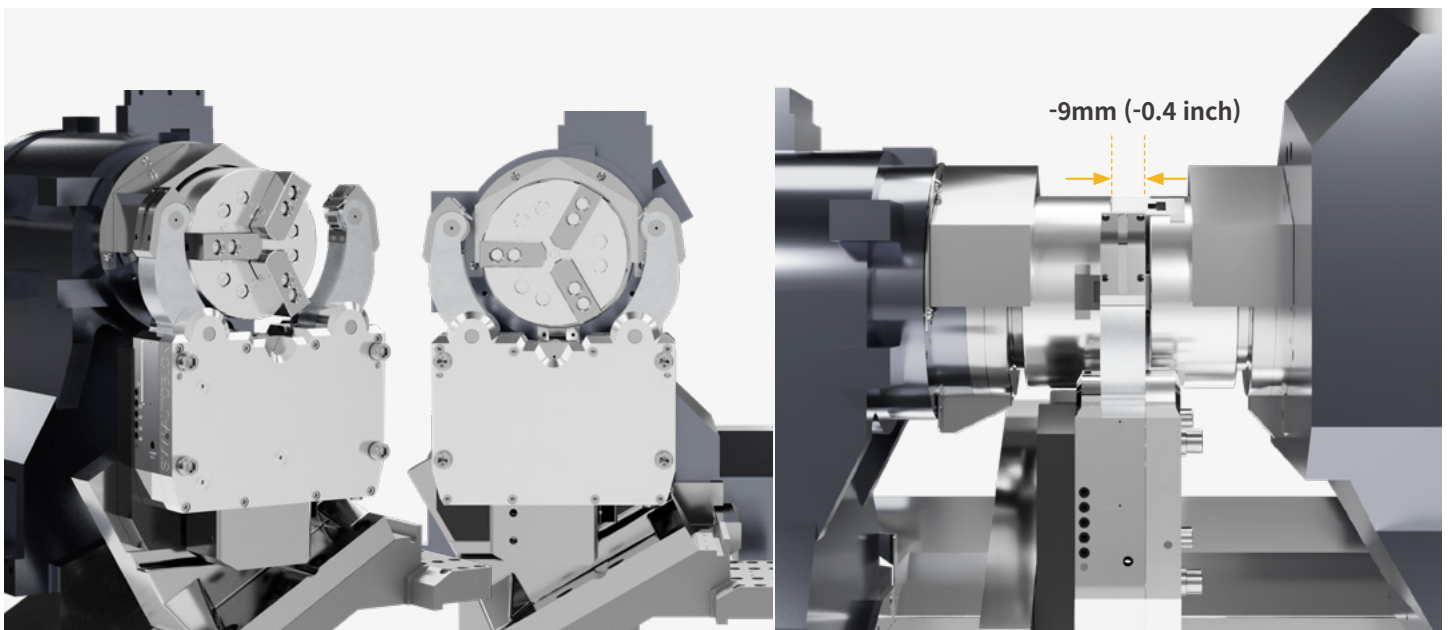

ROBOSOL | IN-FACTORY AUTOMATION

Automation is reliably achieved through the Robosol system and Servo Part Catcher developed by our team. Its modular design structure allows for easy integration into various production lines with minimal modifications, and designed to support detailed operation customization based on site conditions and work characteristics. As a result, it significantly reduces installation time and maintenance burden while simultaneously improving production efficiency and enhancing the reliability of overall process operations.

- Robot Payload :
Standard 35 kg (77.2 lb), Max. 50 kg (110.2 lb)
- Handle size length (Min/max) :
20/150 mm (0.8/5.9 inch),
Diameter(Min/Max) : 30/200 mm (1.2/7.9 inch)
- Gripper weight : 8.6 kg (19.0 lb)
- Gripper design, TC tool change system
- Regulation certification scope, such as CE : CE
- Workpiece loading capacity
 - Ø200*5ea/Tray • Ø150*10ea/Tray
 - Ø100*22ea/Tray • Ø75*39ea/Tray
 - Ø50*68ea/Tray • Ø30*163ea/Tray
- Applicable models :
Small and medium TC/MC

Drawer type | One-time set-up, quantity increase automation solution for high-mix, low-volume production

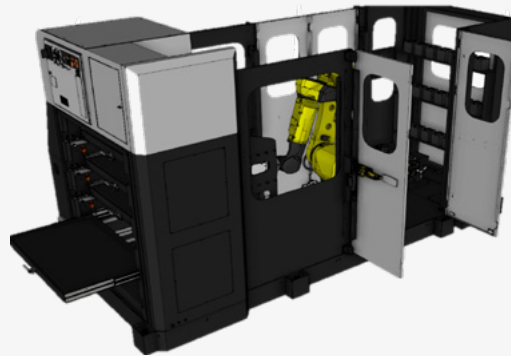

NEW

- Robot Payload : Standard 35kg (77.2 lb)
- Handle size (length, diameter)
Length (Min./Max.) : 20/400mm (0.8/15.7 inch),
Diameter (Min./Max.) : 30/160mm (1.2/6.3 inch)
- Gripper weight : 8.6 kg (19.0 lb)
- Customizable range :
Gripper design, safety fence
- Regulation certification scope,
such as CE : CE
- Workpiece loading capacity
 - Ø200*5ea/Tray • Ø160*7ea/Tray
 - Ø100*22ea/Tray • Ø75*33ea/Tray
 - Ø50*61ea/Tray • Ø30*145ea/Tray
- Applicable models :
Small and medium TC/MC

Turn Table type | Optimal automation solution for small quantity batch production



NEW

- Payload : 4 kg (8.8 lb)
- Handle size :
200 mm (7.9 inch), 80 mm (3.1 inch)

Servo Part catcher (Part Conveyor)



COBOSOL

Flexible automation of work processes can be implemented, based on our self-developed collaborative robot (Cobot). As it is designed to enable safe collaboration between humans and robots, the burden of repetitive tasks can be reduced, and productivity can be enhanced. It also can be flexibly arranged to suit various production environments and layouts, and can be easily adjusted according to working conditions, which minimizes installation and changeover times, while significantly improving production efficiency and workplace safety.

- Robot Payload :
 - Standard 10kg (22.0 lb), Max. 20kg (44.1 lb)
- Handle size length : 15/250 mm (0.6/9.8 inch),
Diameter (Min./Max.) : 30/70 mm (1.2/2.8 inch)
- Gripper weight : 3.7 kg (8.2 lb)
- Customizable range :
 - Gripper, Auto jig changer, vision camera
- Regulation certification scope, such as CE : CE
- Workpiece loading capacity
 - Ø70*16ea/Tray
 - Ø50*25ea/Tray
 - Ø30*36ea/Tray
- Applicable models :
 - Small and medium TC/MC, DVF 4000

COBOSOL Basic | Compact collaborative automation solution for small quantity batch production



- Robot Payload : 20 kg (44.1 lb)
- Handle size diameter (Min./Max.) :
140/300 mm (0.6/11.8 inch), Disc shape
- Gripper weight : Special
- Customizable range : Gripper, vision camera
- Regulation certification scope, such as CE : x
- Workpiece loading capacity :
 - 40 pcs (based on 20 mm (0.8 inch) thickness)
- Applicable models : Small and medium TC

COBOSOL Lift | Lift-type collaborative automation solution for disc-shaped workpieces



- Robot Payload : Standard 20 kg (44.1 lb)
- Handle size length (Min./Max.) :
10/120 mm (0.4/4.7 inch),
Diameter (Min./Max.) : 24/100 mm (0.9/3.9 inch)
- Gripper weight : 4.3 kg (9.5 lb)
- Customizable range : Gripper, 2-stage drawer
(maximum length - 250 mm (9.8 inch))
- Regulation certification scope, such as CE : CE
- Workpiece loading capacity
 - Ø100*13ea/Tray • Ø75*25ea/Tray
 - Ø52*41ea/Tray • Ø40*61ea/Tray
 - 30*85ea/Tray
- Applicable models :
 - Small and medium TC/MC, DVF 4000

Drawer | One-time set-up, quantity increase collaborative automation solution for high-mix, low-volume production



FANUC 0i PLUS

FANUC 0i Plus is a high-performance CNC controller featuring an intuitive 15-inch touch panel and a newly designed user interface (OP), which significantly enhances operational convenience and work efficiency. With a simple and efficient UI layout, FANUC 0i Plus allows users of all levels to quickly configure settings and perform stable control reliably.

15" Touch screen + New OP

DN Solutions Fanuc 31iB/B5 Plus' operation panel enhances operating convenience by incorporating common-design buttons and layout. It features a Qwerty keyboard for fast and easy data input and operation.

FANUC 0i Plus

- 15-inch color display
- Intuitive and user-friendly design

USB and PCMCIA card QWERTY keyboard

- EZ-Guide i standard
- Ergonomic operator panel
- 4MB Memory
- Hot keys
- Enhance AICC BLOCK
- Touch pen provided as standard



iHMI touchscreen

iHMI provides an intuitive interface that uses a touchscreen for quick and easy operation.

Range of applications

Providing various applications related to planning, machining, improvement and utility, for customer convenience.



NUMERIC CONTROL SPECIFICATIONS



Description	Item	Specifications	DNX2100	DNX2100S	DNX2100B	DNX2100SB	
Controlled axis	Controlled axes	Note *1) {Z2} could be supplied as Servo steady rest option.	7 (X, Z, C, B, Y, A, {Z2})	8 (X, Z, C1, B, Y, C2, A, {Z2})	7 (X, Z, C, B, Y, A, {Z2})	8 (X, Z, C1, B, Y, C2, A, {Z2})	
	Simultaneously controlled axes		4 axes (Upper X, Z, C, Y) + 1 axes (Lower {Z2})	4 axes (Upper X, Z, C1, Y) + 1 axes (Lower C2, A, {Z2})	4 axes (Upper X, Z, C, Y) + 1 axes (Lower {Z2})	4 axes (Upper X, Z, C1, Y) + 1 axes (Lower C2, A, {Z2})	
Data input/output	Fast data server		○	○	○	○	
	Memory card input/output		●	●	●	●	
	USB memory input/output		●	●	●	●	
	Large capacity memory_2GB		○	○	○	○	
Interface function	Embedded ethernet		●	●	●	●	
	Fast ethernet		○	○	○	○	
Operation	DNC Operation	Included in RS232C interface.	●	●	●	●	
	DNC Operation with memory card		●	●	●	●	
Feed function	AI contour control I	G5.1 Q_, 40 Blocks	●	●	●	●	
	AI contour control II	G5.1 Q_, 200 Blocks	○	○	○	○	
Operation guidance function	EZ Guide I (Conversational Programming Solution)		●	●	●	●	
	iHMI with machining cycle		●	●	●	●	
	EZ Operation package		●	●	●	●	
Setting and display	CNC screen dual display function		●	●	●	●	
Others	Display unit	15" color LCD with touch panel	●	●	●	●	
	ATC Graphic panel	7" color LCD with touch panel	●	●	●	●	
	Part program storage size & Number of registerable programs	640M(256KB)_500 programs		X	X	X	X
		1280M(512KB)_1000 programs		X	X	X	X
		2560M(1MB)_1000 programs		X	X	X	X
	5120M(2MB)_1000 programs		●	●	●	●	

CONVENIENT OPERATION

The EZ WORK function provides a wide range of support functions, including machine setup assistance, operation guidance, and fault alerts. With intuitive help content and maintenance instructions, it improves operator understanding and reduces the likelihood of errors. Real-time data, such as tool and load monitoring, enhances process stability. Altogether, these functions contribute to maximizing operator convenience and efficiency of the production site.

EZ WORK function

Tool load monitoring, Setup guide, Status monitoring, Operation and Recovery guide can provide more convenience and efficiency increasing for user operation.



Tool load monitoring

Real-time tool load monitoring and display various tooling information.

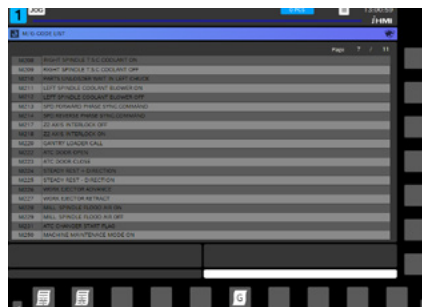

Operation and Recovery guide

Provides step-by-step operation guides and help so even unskilled users can operate it safely and easily.



Thermal Compensation

Improve the machining precision through temperature sensor detection and deflection compensation of the structure in real-time.



Setup guide

Displays the operation status up to now and guides the next step when setting up the machine.

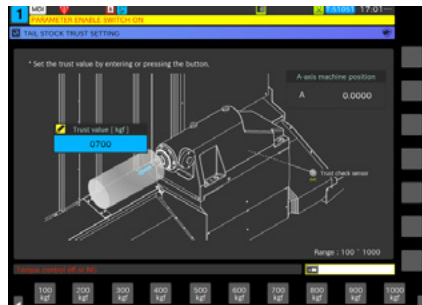

CONVENIENT OPERATION

SIEMENS SINUMERIK ONE

22 inch display + New OP

Two path programs are displayed simultaneously in the large 22-inch screen for enhanced user convenience.

- 22-inch display
- 6GB user memory
- USB (standard)
- QWERTY keyboard



Convenient conversational functionality

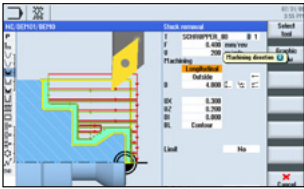

Shopmill / Shopturn

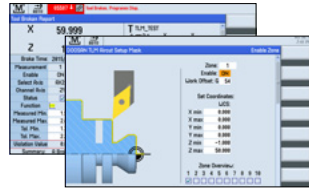

Tool load monitoring

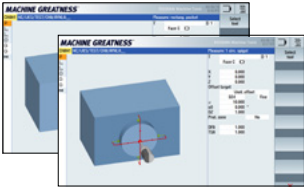

Measuring cycle

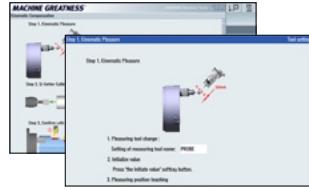

Intelligent kinematic compensation function

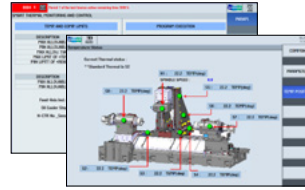

Temperature compensation function



Collision avoidance function

NUMERIC CONTROL SPECIFICATIONS

SIEMENS

Item	Specifications	SIEMENS (SINUMERIK ONE)
Simultaneously controlled axes	Positioning(G00)/Linear interpolation(G01) : 5 axes Circular interpolation(G02, G03) : 2 axes	○
Advanced surface		●
Linear interpolation	Max. 4	●
Circular interpolation	G02, G03	●
Inverse time feedrate	G93	●
Helical interpolation		●
Coupling	CP-Basic	●
Number of tools/cutting edges in tool list	NCU1740 for ONE	600/1500
High-level CNC language with		3000
• Look ahead number of blocks		1000
• Look Ahead, recorded part program blocks		● (10MB)
• CNC user memory(buffered) for CNC part program	NCU1740(std.) NCU1760(option)	○ (100MB)
Option P77 for CNC user memory	NCU1740(std.) NCU1760(option)	○ (40GB)
Option P12 & option P77 for CNC user memory	NCU1740(std.) NCU1760(option) & IPC427E type	○ (6GB)
Option P75 for CNC user memory	Option P77 + option P12	○
• Execution from external storage devices (EES / Using by USB or Network)		(without limit)
• HMI user memory for CNC part program		●
NCU1740		●
NCU1760		○
TC2200		●
MCP2200		●
IPC427E		○
Contour handwheel		○
Integrate screens in SINUMERIK Operate with		●
Cross-mode actions (ASUPs and synchronized		●
Collision avoidance (machine, working area)		●
DXF-reader function		○

STANDARD | OPTIONAL SPECIFICATIONS

Description	Details		Essential		Performance		Advanced	
			DNX 2100	[DNX 2100B]	DNX 2100S	[DNX 2100SB]	DNX 2100SB	
Tool type	HSK-A63			●		●	●	
	CAPTO C6			○		○	○	
Automatic Tool Changer	7" operation touch panel			●		●	●	
Tool magazine	30 tools			●		●	X	
	60 tools			○		○	●	
Milling spindle	12000 r/min			●		●	●	
Work holding device	Left spindle	Hydraulic chuck 8"	●	[X]	●	[X]	X	
		Hydraulic chuck 10"	○	[●]	○	[●]	●	
		Hydraulic chuck 12"	X	[○]	X	[○]	○	
	Right spindle	Hydraulic chuck 8"		X		●	●	
		Hydraulic chuck 10"		X		○	○	
	CPS(Chuck Position Sensor)	Left spindle		⊕		⊕	⊕	
		Right spindle		X		●	●	
	Chuck clamp & Unclamp confirmation			○		●	●	
	Servo driven steady rest (Z-movement)	SLU-3.1 (Ø20~Ø165)			○		○	○
		SLU-3.2 (Ø50~Ø200)			○		○	○
		K3.0 (Ø65~Ø235)			○		○	○
		STA-3.1 (Ø20~Ø165)			○		○	○
STA-3.2 (Ø50~Ø200)			○		○	○		
Coolant	T-T-C (Milling spindle)			●		●	○	
	Pressure 2.0MPa (290 psi)/Element filter			○		○	●	
	Pressure 7.0MPa (1015 psi)/Cyclone filter/Chiller			○		○	○	
	Coolant pressure switch (milling spindle)			●		●	●	
Oil skimmer			●		●	●		
Level switch (low sensing level)			●		●	●		
Chip disposal	Chip conveyor (Right disposal)			●		●	●	
	Chip bucket			○		○	○	
	Air blow for chuck jaw cleaning (left or right spindle)			●		●	●	
	Coolant for chuck jaw cleaning (left or right spindle)			○		●	●	
	Spindle-through air injection device (left or right spindle)			○		○	○	
	Spindle-through coolant injection device (left spindle)			○		○	○	
	Spindle-through coolant injection device (right spindle)			X		○	●	
	Shower coolant (0.75kW, 30 liter/min)			○		○	○	
	Coolant gun			●		●	●	
	Air gun			○		○	○	
Precision enhancement device	Thermal displacement compensation system			●		●	●	
	Coolant chiller (temperature control)*			○		○	●	
	Linear scale (X-axis)			●		●	●	
	Linear scale (Y-axis)			○		●	●	
	Linear scale (Z-axis)			○		●	●	
Measurement	Oil coolant flow detector			○		○	○	
	Auto tool setter(Milling spindle, touch)			○		○	○	
	Auto tool setter(Milling spindle, non-touch, NC4)			○		○	○	
	Automatic tool breakage detection device (BK MIKRO)			○		○	○	
	Auto workpiece measurement (RMP60)			○		○	○	
Automation	Part catcher and part conveyor			○		○	○	
	Workpiece discharge device (Ejector, right spindle direction, TSC/TSA selectable)			X		○	○	
	Bar feeder interface			○		○	○	
	Robot interface			○		○	○	
Others	Automatic front door (with safety device)			○		○	○	
	Tool monitoring system			●		●	●	
	Rotary type window wipe			○		○	○	
	Intelligent kinematic compensation for multi-tasking (software only)			●		●	●	
	Intelligent kinematic compensation for multi-tasking (Datum ball gage)			○		○	○	
	AUTOMATIC POWER OFF			○		○	○	
	Operation panel screen size		15 inch (FANUC)	●		●	●	
		22 inch (Siemens)	●		●	●		
Standard Accessories	ADDITIONAL PORTABLE MPG			○		●	●	
	Foundation bolt for anchoring			●		●	●	
Customized special option	Air limit sensing on chuck_Preparation			⊕		⊕	⊕	
	Left/Right spindle air curtain			⊕		⊕	⊕	
	Coolant for milling spindle_Multi pressure			⊕		⊕	●	
	MQL (Minimum quantity lubrication syetem)			⊕		⊕	⊕	
	Additional work light for ATC magazine			⊕		⊕	⊕	

* The coolant chiller is included when the 70bar T-T-C option is selected.

DNX GLOBAL 3 PACKAGES

- **8 inch main spindle**
- **30Tool** w/7 inch magazine screen
- Tailstock
- Foot switch (chuck clamp/unclamp)
- 3 color lights
- Linear scale X-axis
- Thermal displacement compensation function
- DN Solutions tool monitoring
- DSSV *

** DNSolutions Spindle Speed Variation: reduces chatter by adjusting the spindle speed of the main spindle at a certain frequency and amplitude during turning operations to improve the surface roughness.*

Chip conveyor/Cutting oil package 1

- Coolant gun
- Hinge type chip conveyor
- 20 bar TSC (milling spindle)
- 4.5 bar flushing coolant
- Coolant level switch
- Coolant pressure switch

**DNX 2100
Essential**

DNX 2100

- **Essential options included as standard**
- **No tailstock X**



- **8-inch sub spindle + linear position sensor**
- Dual pressure chucking
- Chuck coolant left/right
- Linear scale Y/Z-axis
- MPG (handwheel)
- Oil mist collector preparation

Chip conveyor/Cutting oil package 1

- Hinge coolant gun
- Hinge type chip conveyor
- 20bar TSC (milling spindle)
- 4.5 bar flushing coolant
- Coolant level switch
- Coolant pressure switch
- Oil skimmer (belt type)

**DNX 2100
Performance**

DNX 2100S

- **Performance package option included as standard**



- **10 inch main spindle**
- **60 tool**
- **Sub spindle TSC (Only sub)**

Chip conveyor/Cutting oil package 2

- Coolant gun
- Hinge type chip conveyor
- 70 bar 7 steps programmable TSC (milling spindle)
- Coolant chiller
- 4.5 bar flushing coolant
- Coolant level switch
- Coolant pressure switch
- Oil skimmer (belt type)

**DNX 2100
Advanced**

DNX 2100SB

PERIPHERAL EQUIPMENT

Servo steady rest

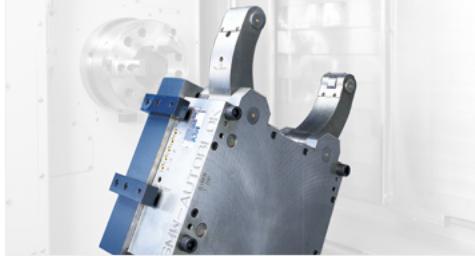

The servo steady rest is a peripheral device that supports the workpiece so that it does not bend or deform when machining a long workpiece.

The steady rest can be parked.*

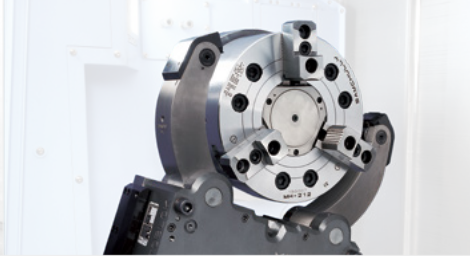

When the steady rest is not used, it can be moved/ fixed below the first spindle chuck to prevent interference during machining a general workpiece.

** This function is only available on DNX2100/S(8 inch chuck) with K3.0 steady rest selected.*

방진구(작동 영역)	DNX2100/S	DNX2100B/SB
SLU-3.1 (Ø20~Ø165)	○	○
SLU-3.2 (Ø50~Ø200)	○	○
K3.0 (Ø65~Ø235)	○ (including parking function)	○
STA-3.1 (Ø20~Ø165)	○	○
STA-3.2 (Ø50~Ø200)	○	○

Chip conveyor (right side)

This conveyor provides an excellent chip discharge effect. It is designed with a stable structure and easy to use and maintain. The efficiency of workspace can be increased by choosing the right type.

Name	Hinge belt	Magnetic scraper	Drum filter + Hinge scraper (double type)
Application	Steel	Casting	Steel, castings, non-ferrous metals
Features	<ul style="list-style-type: none"> Common use Suitable for steel materials with chips longer than 30 mm 	<ul style="list-style-type: none"> Easy maintenance and service Chips are scraped off with a scraper and discharged 	<ul style="list-style-type: none"> Suitable for both long and short chips Coolant filtration function
Shape			

Servo part catcher considering both speed and quality

The slim design, with no protruding parts on the front, and the integration of a servo motor significantly enhance feed speed. The projection distance can be easily set using command-based control from the operation panel. Thanks to the use of soft materials, marking on the workpiece is minimized, and materials weighing up to 4 kg can be handled reliably.

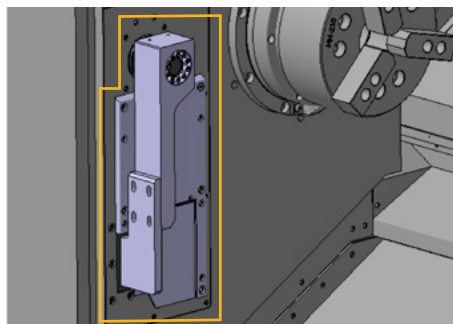

Tool length measuring device



A swing arm type tool length measuring device that can measure data such as tool length and wear.

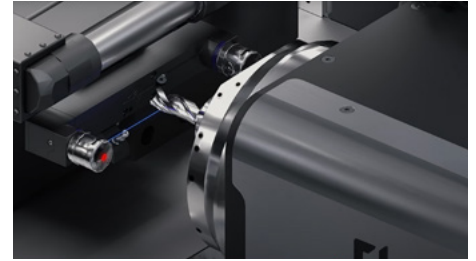

A non-contact laser type tool measuring device is easy to apply to ultra-precision tools or small tools, and provides excellent measurement repeatability.

Coolant cooling device (recommended)

It is strongly recommended to use a coolant chiller when using non-water-based coolant or operating high-pressure coolant systems exceeding 1.5 kW, in order to prevent temperature increase and minimize thermal deformation.

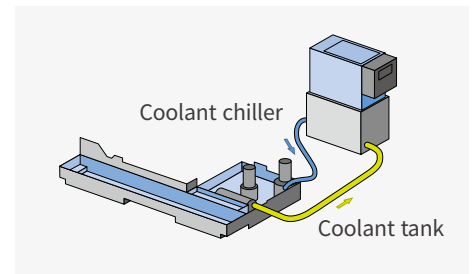

POWER | TORQUE

FANUC

8 inch_Left / Right spindle

Max. spindle speed

5000 r/min

Max. spindle motor power

18.5 kW
(24.8 Hp)

Max. spindle torque

326 N·m
(240.6 ft-lbs)

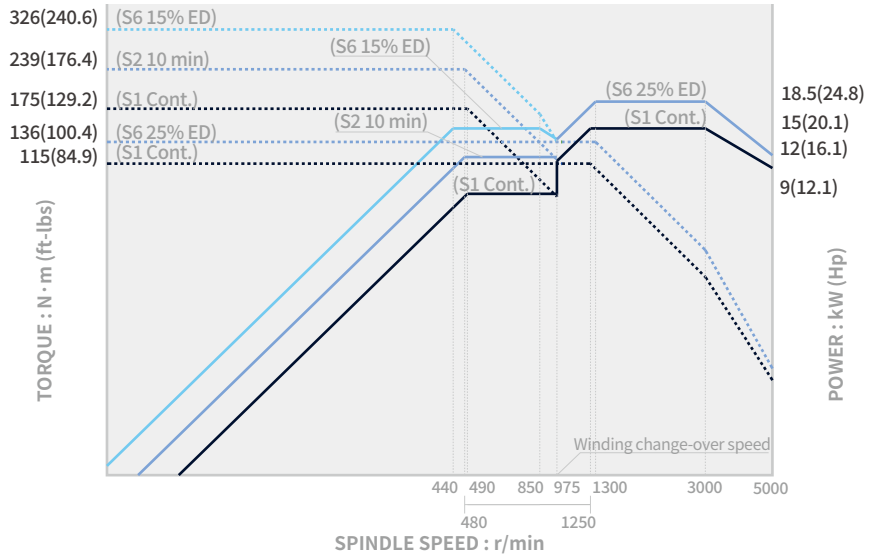

10 inch_Left spindle

Max. spindle speed

4000 r/min

Max. spindle motor power

22 kW
(29.5 Hp)

Max. spindle torque

456 N·m
(336.5 ft-lbs)

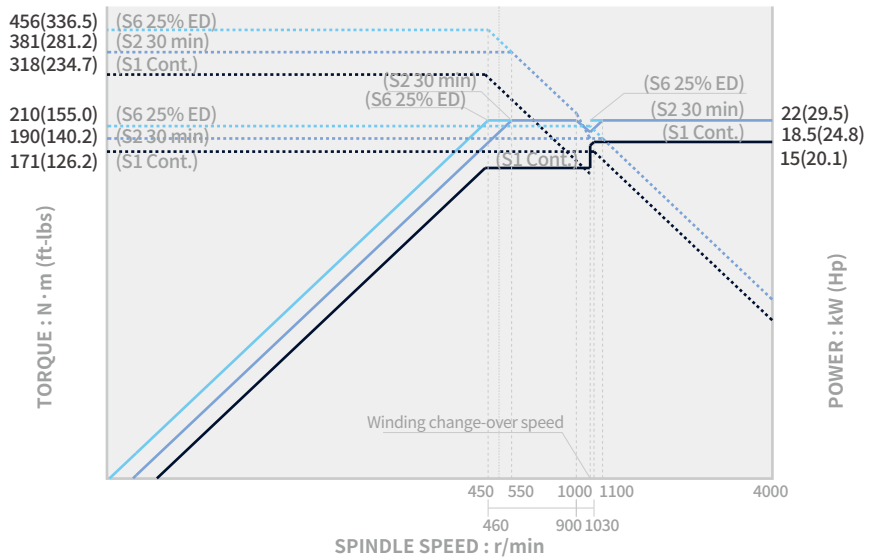

Milling spindle

Max. spindle speed

12000 r/min

Max. spindle motor power

18.5 kW
(24.8 Hp)

Max. spindle torque

58 N·m
(42.8 ft-lbs)

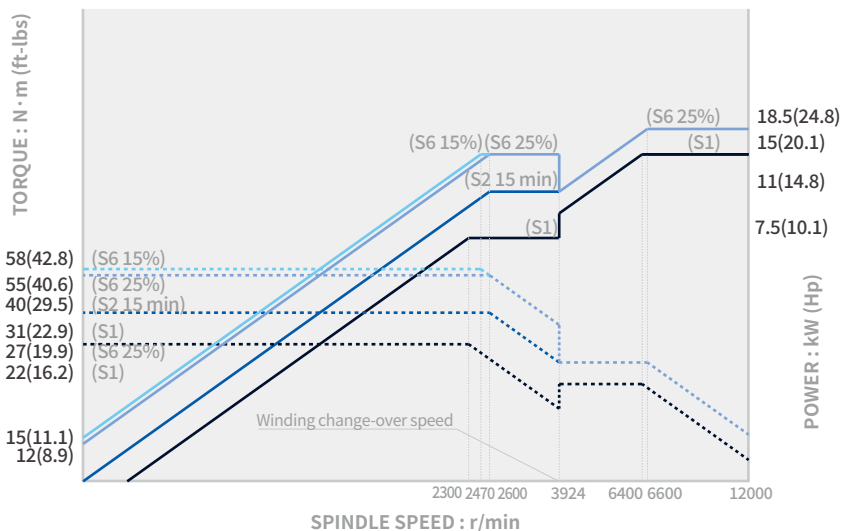

POWER | TORQUE

SIEMENS

8 inch_Left / Right spindle

Max. spindle speed

5000 r/min

Max. spindle motor power

23.2 kW
(31.1 Hp)

Max. spindle torque

381 N·m
(281.2 ft-lbs)

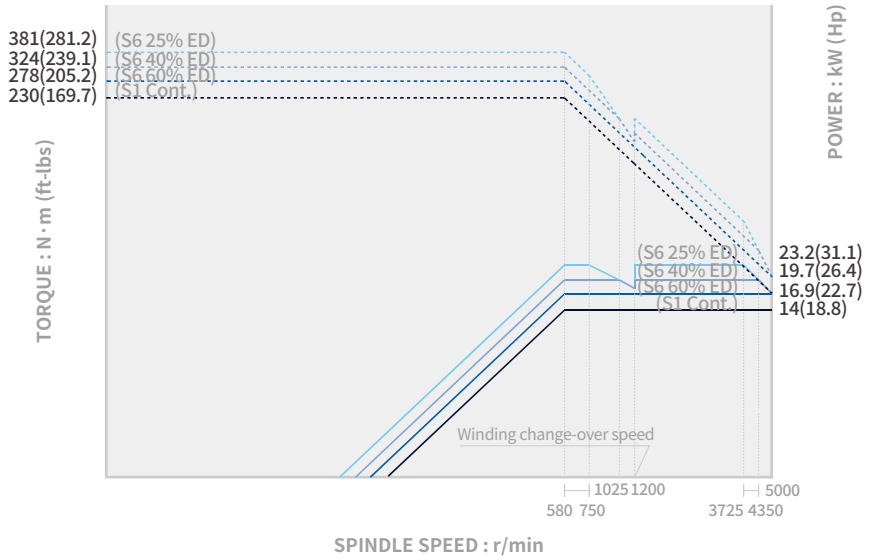

10 inch_Left spindle

Max. spindle speed

4000 r/min

Max. spindle motor power

23.5 kW
(31.5 Hp)

Max. spindle torque

584 N·m
(431.0 ft-lbs)

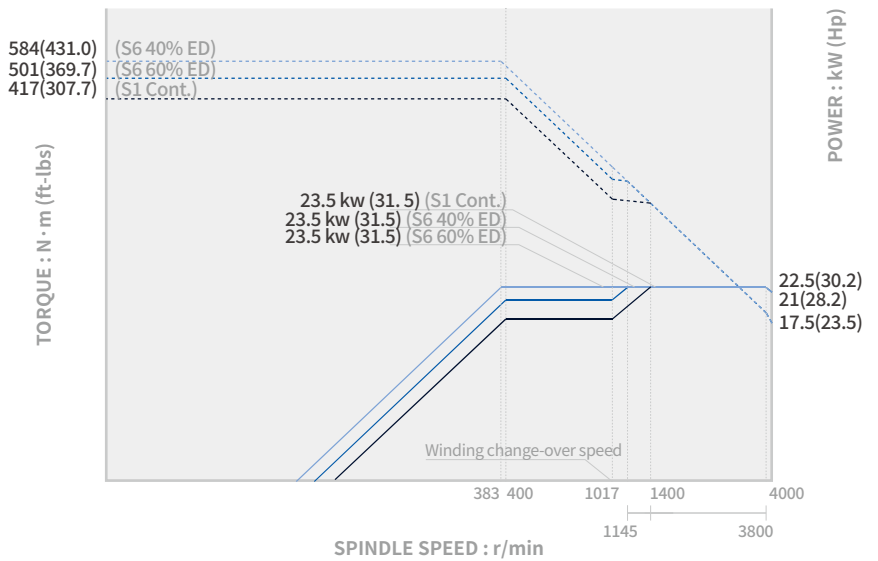

Milling spindle

Max. spindle speed

12000 r/min

Max. spindle motor power

14.9 kW
(20.0 Hp)

104 N·m
(76.8 ft-lbs)

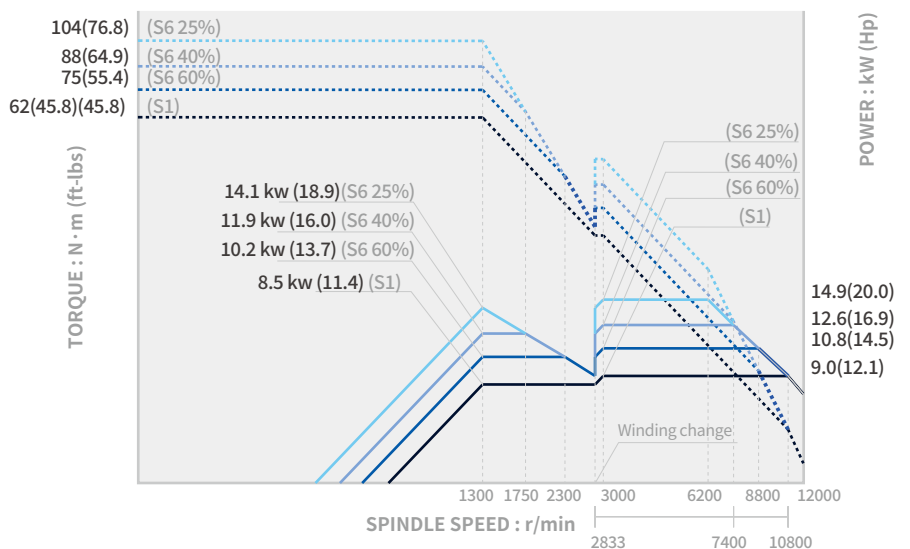

EXTERNAL DIMENSIONS

FANUC

Unit : mm (inch)

Top view

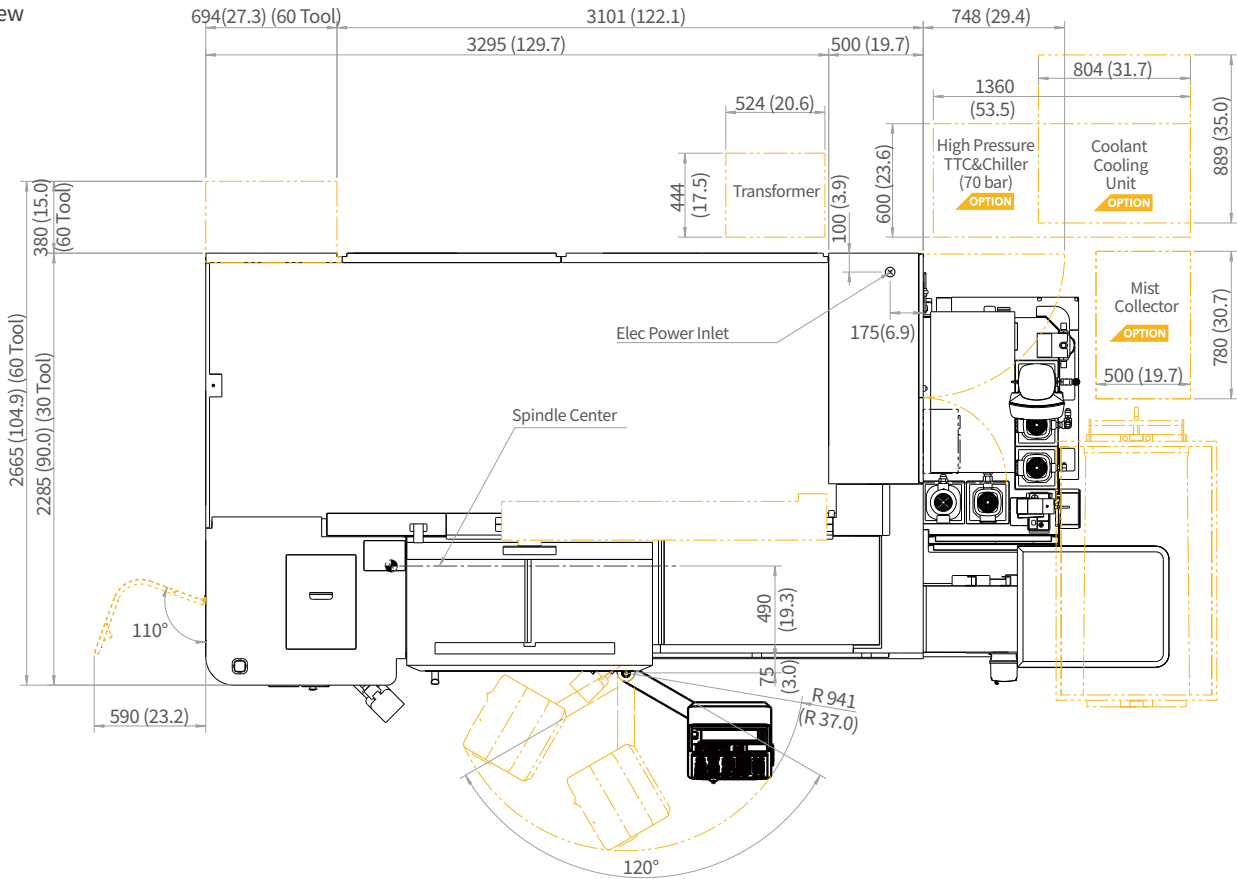

Front view

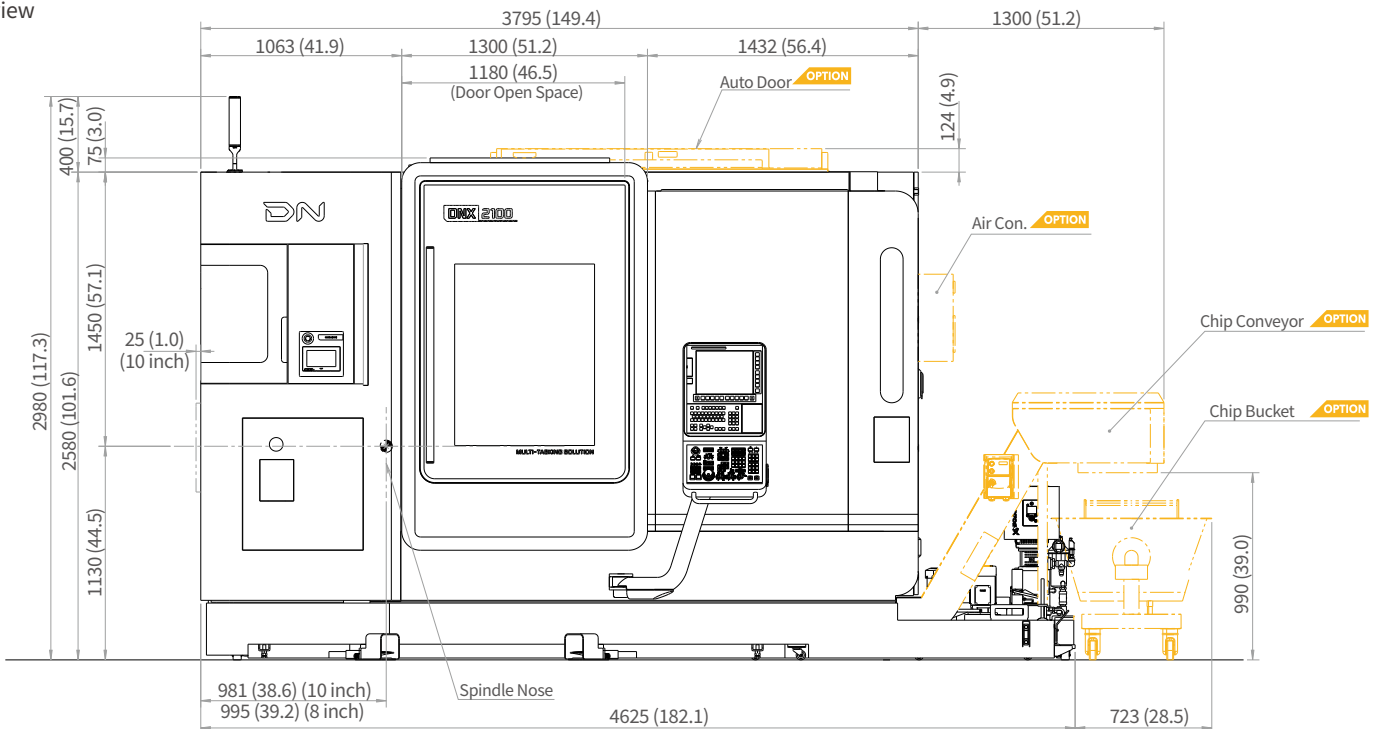

EXTERNAL DIMENSIONS

SIEMENS

Unit : mm (inch)

Top view

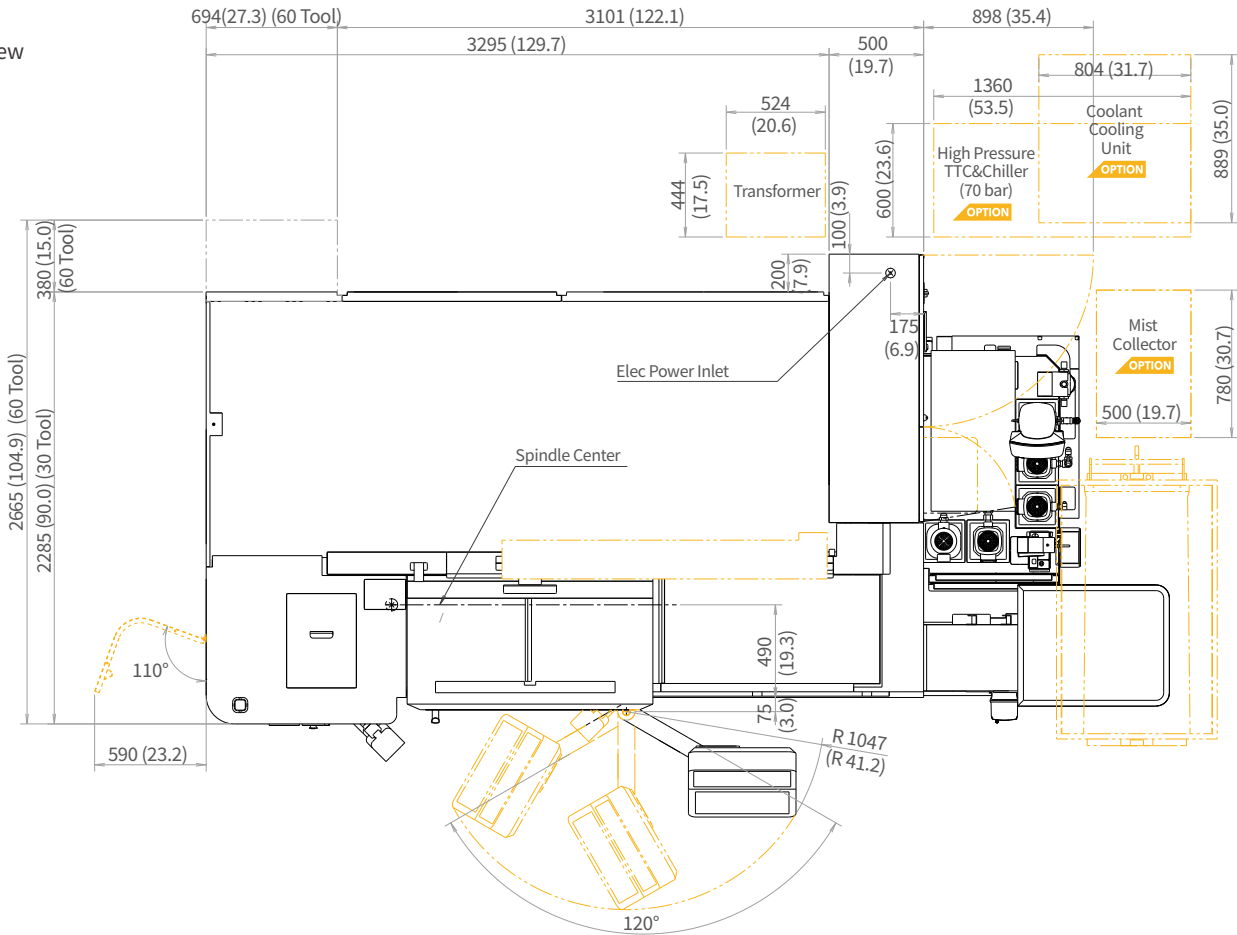

Front view

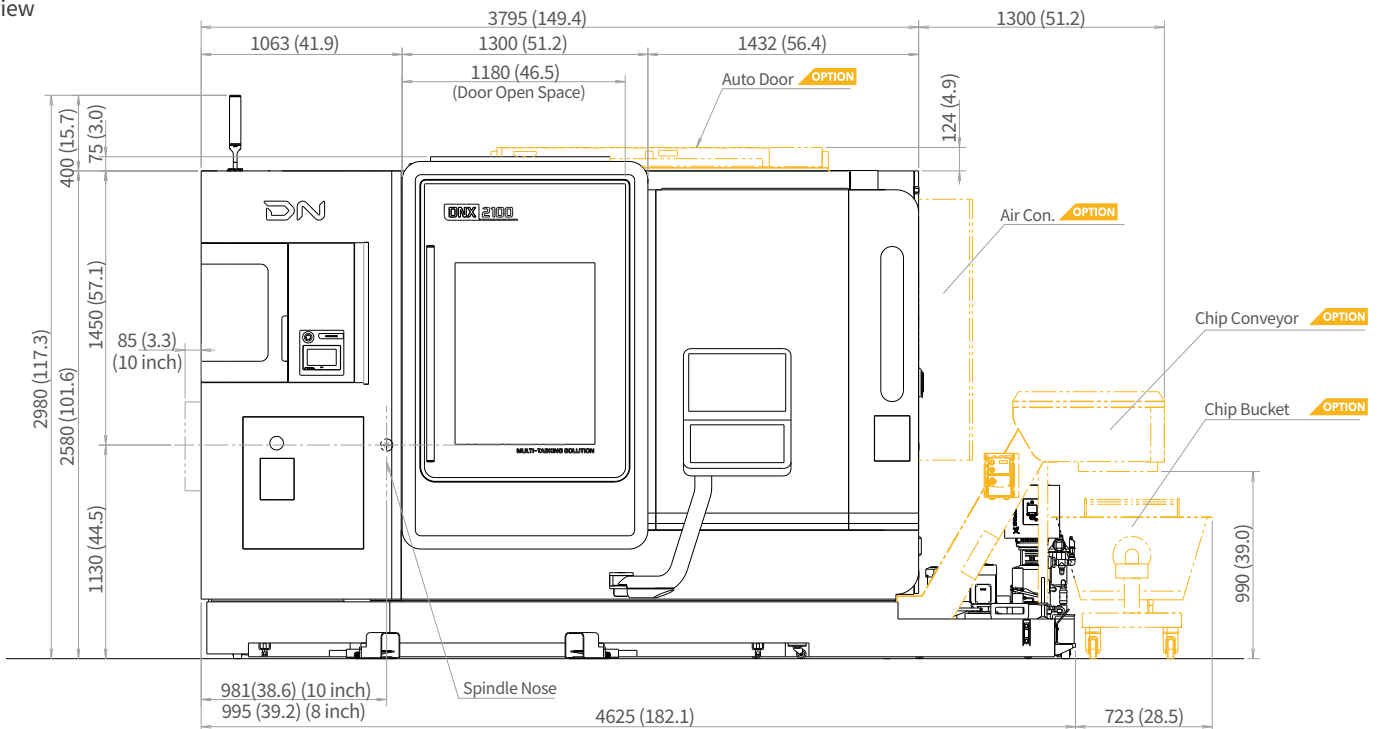

WORKING RANGE

Unit : mm (inch)

DNX2100/B

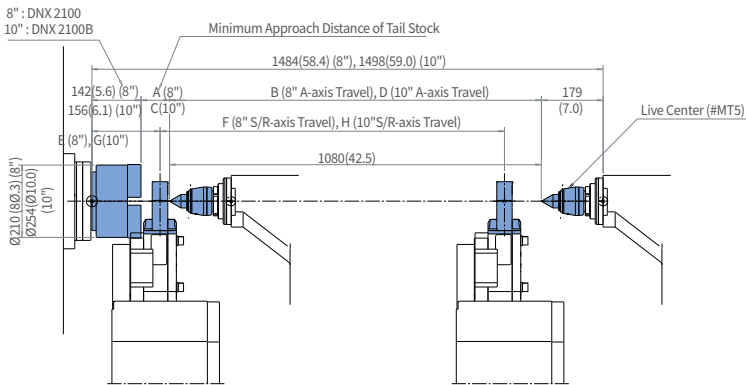

SLU 3.0

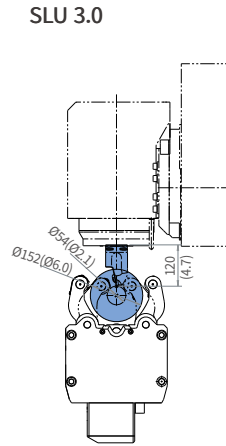

SLU 3.1

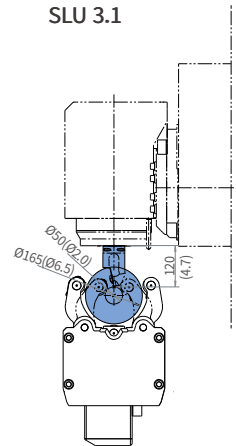

Steady Rest (operating area)	Tail Stock				Steady Rest			
	DNX2100(8")		DNX2100B(10")		DNX2100(8")		DNX2100B(10")	
	A	B	C	D	E	F	G	H
SLU-3.0	83(3.3)	1080(42.5)	83(3.3)	1080(42.5)	197.5(7.8)	1000(39.4)	211.5(8.3)	1000(39.4)
SLU-3.1	83(3.3)	1080(42.5)	83(3.3)	1080(42.5)	197.5(7.8)	1000(39.4)	211.5(8.3)	1000(39.4)
SLU-3.2	83(3.3)	1080(42.5)	83(3.3)	1080(42.5)	197.5(7.8)	1000(39.4)	211.5(8.3)	1000(39.4)
K 3.0	3(0.1)	1160(45.7)	83(3.3)	1080(42.5)	117.5(4.6)	1080(42.5)	211.5(8.3)	1000(39.4)

DNX2100S/SB

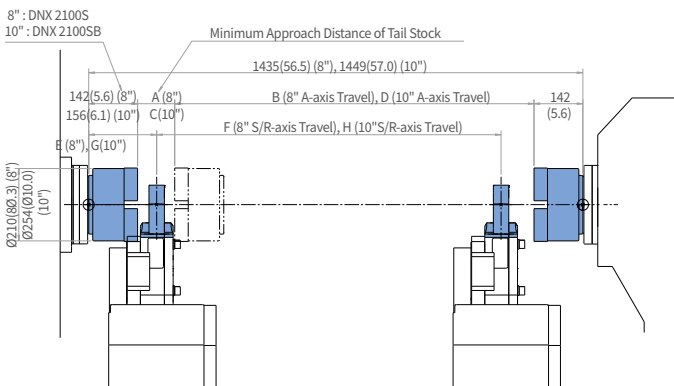

SLU 3.2

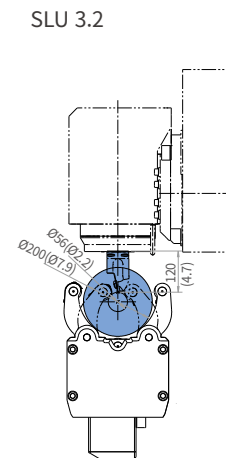

K 3.0

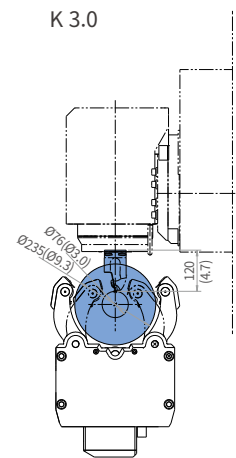

Steady Rest (operating area)	Right Spindle				Steady Rest			
	DNX2100S(8")		DNX2100SB(10")		DNX2100S(8")		DNX2100SB(10")	
	A	B	C	D	E	F	G	H
SLU-3.0	108(4.3)	1043(41.1)	108(4.3)	1043(41.1)	197.5(7.8)	1000(39.4)	211.5(8.3)	1000(39.4)
SLU-3.1	108(4.3)	1043(41.1)	108(4.3)	1043(41.1)	197.5(7.8)	1000(39.4)	211.5(8.3)	1000(39.4)
SLU-3.2	108(4.3)	1043(41.1)	108(4.3)	1043(41.1)	197.5(7.8)	1000(39.4)	211.5(8.3)	1000(39.4)
K 3.0	-9(-0.4)	1160(45.7)	108(4.3)	1043(41.1)	117.5(4.6)	1080(42.5)	211.5(8.3)	1000(39.4)

MACHINE SPECIFICATIONS

FANUC

Description		Unit	Essential		Performance		Advanced		
			DNX 2100	[DNX 2100B]	DNX 2100S	[DNX 2100SB]	DNX 2100SB		
Capacity	Swing over bed	mm (inch)	635 (468.6)						
	Recommended turning diameter	mm (inch)	210 (155.0)	[255 (188.2)]	210 (155.0)	[255 (188.2)]	255 (188.2)		
	Max. machining diameter	mm (inch)	410 (302.6)						
	Max. turning length	mm (inch)	1100 (811.8)						
	Chuck size - Left spindle	inch	8	[10]	8	[10]	10		
	Chuck size - Right spindle	inch	-			8			
	Chuck work weight (include chuck)	kg (lb)	150 (330.7)	[260 (573.2)]	150 (330.7)	[260 (573.2)]	260 (573.2)		
	Shaft work weight (include chuck)	kg (lb)	300 (661.4)	[520 (1146.4)]	300 (661.4)	[520 (1146.4)]	520 (1146.4)		
Bar working diameter	mm (inch)	67 (2.6)	[81(3.2)]	67 (2.6)	[81 (3.2)]	81 (3.2)			
Feed system	Travel distance	X-axis	760 (29.9) (-20/+740(-0.8/+29.1))						
		Y-axis	230 (9.1) (±115 (±4.5))						
		Z-axis	1150 (45.3)						
		A-axis	1160 (45.7)						
		B-axis	240 (9.4) (±120 (±4.7))						
	C1-axis / C2-axis		deg	360/-		360/360			
	Rapid traverse rate	X-axis	m/min (ipm)	36 (1417.3)					
		Y-axis	m/min (ipm)	36 (1417.3)					
		Z-axis	m/min (ipm)	36 (1417.3)					
		A-axis	m/min (ipm)	10 (393.7)		30 (1181.1)			
B-axis		r/min	40						
C1-axis / C2-axis		r/min	200/-		200/200				
Left spindle	Max. spindle speed	r/min	5000	[4000]	5000	[4000]	4000		
	Spindle motor power	kW (Hp)	18.5/15 (24.8/20.1) (S6 25%/S1 Cont.)	[22/22/18.5 (29.5/29.5/24.8)] (S6 25%/S2 30min/S1 Cont.)	18.5/15 (24.8/20.1) (S6 25%/S1 Cont.)	[22/22/18.5 (29.5/29.5/24.8)] (S6 25%/S2 30min/S1 Cont.)	22/22/18.5 (29.5/29.5/24.8) (S6 25%/S2 30min/S1 Cont.)		
	Spindle nose specification	ASA	A2-6	[A2-8]	A2-6	[A2-8]	A2-8		
	Spindle bearing diameter (Front)	mm (inch)	110 (4.3)	[130 (5.1)]	110 (4.3)	[130 (5.1)]	130 (5.1)		
	Spindle through hole	mm (inch)	76 (3.0)	[91 (3.6)]	76 (3.0)	[91 (3.6)]	91 (3.6)		
	Min. spindle indexing angle (C1-axis)	deg	0.001						
Right spindle	Max. spindle speed	r/min	-		5000				
	Spindle motor power	kW (Hp)	-		18.5/15 (24.8/20.1) (S6 25%/S1 Cont.)				
	Spindle nose specification	ASA	-		A2-6				
	Spindle bearing diameter (Front)	mm (inch)	-		110 (4.3)				
	Spindle through hole	mm (inch)	-		76 (3.0)				
	Min. spindle indexing angle (C2-axis)	deg	-		0.001				
Milling Spindle	Max. spindle speed	r/min	12000						
	Spindle motor power	kW (Hp)	18.5/15 (24.8/20.1) (S6 25%/S1 Cont.)						
	Min. spindle indexing angle (B-axis)	deg	0.0001						
Automatic Tool Changer	Tool storage capacity (Max.)		ea		30 {60}		60		
	Tool type		HSK-A63(T63) {CAPTO C6}						
	Max. tool diameter	If there is a tool nearby	mm (inch)	78 (3.1)					
		If there is no tool nearby	mm (inch)	125 (4.9)					
	Max. tool length		mm (inch)	300 (11.8)					
	Max. tool weight		kg (lb)	8 (17.6)					
Max. tool moment		N.m (ft-lbs)	6.6 (4.9)						
Tailstock	Tailstock quill taper	Center {Built-in type dead center}	MT		#5 {#4}		-		
	Tailstock travel		mm (inch)	1160(45.7)		-			
Coolant	Milling spindle coolant pressure		Mpa	2.0 {7.0}		7.0 {2.0}			
Power source	Electric power supply (rated capacity)		kVA	61.70	[63.32]	64.52	[66.13]		
Machine size	Height		mm (inch)	2655					
	Length		mm (inch)	3795 (149.4) (without coolant tank), 4625 (182.1)					
	Width	30 tools	mm (inch)	2285 (90.0)					
		60 tools	mm (inch)	[2665 (104.9)]					
	Weight		kg (lb)	10500 (23148.2)	[10650(23478.9)]	10850 (23919.8)	[11000 (24250.5)]	[11000 (24250.5)]	
Control	NC system		Fanuc Oi TF Plus						

*{ } : Option

MACHINE SPECIFICATIONS

SIEMENS

Description		Unit	Essential		Performance		Advanced	
			DNX 2100	[DNX 2100B]	DNX 2100S	[DNX 2100SB]	DNX 2100SB	
Capacity	Swing over bed	mm (inch)	635 (468.6)					
	Recommended turning diameter	mm (inch)	210 (155.0)	[255 (188.2)]	210 (155.0)	[255 (188.2)]	255 (188.2)	
	Max. machining diameter	mm (inch)	410 (302.6)					
	Max. turning length	mm (inch)	1100 (811.8)					
	Chuck size - Left spindle	inch	8	[10]	8	[10]	10	
	Chuck size - Right spindle	inch	-				8	
	Chuck work weight (include chuck)	kg (lb)	150 (330.7)	[260 (573.2)]	150 (330.7)	[260 (573.2)]	260 (573.2)	
	Shaft work weight (include chuck)	kg (lb)	300 (661.4)	[520 (1146.4)]	300 (661.4)	[520 (1146.4)]	520 (1146.4)	
	Bar working diameter	mm (inch)	67 (2.6)	[81(3.2)]	67 (2.6)	[81 (3.2)]	81 (3.2)	
Feed system	Travel distance	X-axis	760 (29.9) (-20/+740(-0.8/+29.1))					
		Y-axis	230 (9.1) (± 115 (±4.5))					
		Z-axis	1150 (45.3)					
		A-axis	1160 (45.7)					
		B-axis	240 (9.4) (± 120 (±4.7))					
	C1-axis / C2-axis		360/-		360/360			
	Rapid traverse rate	X-axis	m/min (ipm)		40 (1574.8)			
		Y-axis	m/min (ipm)		40 (1574.8)			
		Z-axis	m/min (ipm)		40 (1574.8)			
		A-axis	m/min (ipm)		10 (393.7)	30 (1181.1)		
B-axis		r/min		40				
C1-axis / C2-axis		r/min		200/-	200/200			
Left spindle	Max. spindle speed	r/min	5000	[4000]	5000	[4000]	4000	
	Spindle motor power	kW (Hp)	23.2/19.7/16.9/14 (31.1/26.4/22.7/18.8) (S6 25%/S6 40%/S6 60%/S1 Cont.)	[23.5/23.5/23.5 (31.5/31.5/31.5) (S6 40%/S6 60%/S1 Cont.)]	23.2/19.7/16.9/14 (31.1/26.4/22.7/18.8) (S6 25%/S6 40%/S6 60%/S1 Cont.)	[23.5/23.5/23.5 (31.5/31.5/31.5) (S6 40%/S6 60%/S1 Cont.)]	23.5/23.5/23.5 (31.5/31.5/31.5) (S6 40%/S6 60%/S1 Cont.)	
	Spindle nose specification	ASA	A2-6	[A2-8]	A2-6	[A2-8]	A2-8	
	Spindle bearing diameter (Front)	mm (inch)	110 (4.3)	[130 (5.1)]	110 (4.3)	[130 (5.1)]	130 (5.1)	
	Spindle through hole	mm (inch)	76 (3.0)	[91 (3.6)]	76 (3.0)	[91 (3.6)]	91 (3.6)	
	Min. spindle indexing angle (C1-axis)	deg	0.001					
Right spindle	Max. spindle speed	r/min	-		5000			
	Spindle motor power	kW (Hp)	-		23.2/19.7/16.9/14 (31.1/26.4/22.7/18.8) (S6 25% / S6 40% / S6 60% / S1 Cont.)			
	Spindle nose specification	ASA	-		A2-6			
	Spindle bearing diameter (Front)	mm (inch)	-		110 (4.3)			
	Spindle through hole	mm (inch)	-		76 (3.0)			
Min. spindle indexing angle (C2-axis)	deg	-		0.001				
Milling Spindle	Max. spindle speed	r/min	12000					
	Spindle motor power	kW (Hp)	14.9/12.6/10.8/9.0 (10.1/16.9/14.5/12.1) (S6 25%/S6 40%/S6 60%/S1 Cont.)					
	Min. spindle indexing angle (B-axis)	deg	0.0001					
Automatic Tool Changer	Tool storage capacity (Max.)	ea	30 {60}				60	
	Tool type		HSK-A63(T63) {CAPTO C6}					
	Max. tool diameter	If there is a tool nearby	mm (inch)	78 (3.1)				
		If there is no tool nearby	mm (inch)	125 (4.9)				
	Max. tool length	mm (inch)	300 (11.8)					
	Max. tool weight	kg (lb)	8 (17.6)					
Max. tool moment	N.m (ft-lbs)	6.6 (4.9)						
Tailstock	Tailstock quill taper	MT	#5 {#4}				-	
	Tailstock travel	mm (inch)	1160(45.7)				-	
Coolant	Milling spindle coolant pressure	Mpa	2.0 {7.0}				7.0 {2.0}	
Power source	Electric power supply (rated capacity)	kVA	64.48	[64.82]	90.26	[90.59]	90.59	
Machine size	Height	mm (inch)	2655					
	Length	mm (inch)	3795 (149.4) (without coolant tank), 4625 (182.1)					
	Width	30 tools	mm (inch)	2485 (97.8)				-
		60 tools	mm (inch)	[2665 (104.9)]				2665 (104.9)
Weight	kg (lb)	10500 (23148.2)	[10650(23478.9)]	10850 (23919.8)	[11000 (24250.5)]	[11000 (24250.5)]		
Control	NC system		S-ONE					

*{ } : Option

WHY DN SOLUTIONS

The DN Solutions promise, MACHINE GREATNESS, has two important meanings. The first is simple: DN Solutions makes great machines. The second is a challenge to our end-users. With a product line that is this comprehensive, accurate and reliable, we equip our customers to machine greatness. The big question: *Why should you choose DN Solutions over other options?* Here's why...

UNBEATABLE MACHINES

You won't find a more comprehensive range or a better combination of value, performance and reliability anywhere else.

ROBUST PRODUCT LINE

We offer an impressive range of machine models and hundreds of configurations. Whatever your machining needs and requirements, there's a DN Solutions for you.

READILY AVAILABLE - ANYWHERE IN THE WORLD

Machining centres (including 5-axis machines), lathes, multi-tasking turning centres and mill-turn machines, and horizontal borers with best-in-class specifications are all available...ready to install.

EXPERT SERVICE

Our dedicated, experienced and knowledgeable team is totally committed to improving your productivity, growth and success.

RESPONDING TO CUSTOMERS **ANYTIME, ANYWHERE**

DN SOLUTIONS GLOBAL NETWORK

66 COUNTRIES | **140** + SALES NETWORKS | **3** FACTORIES | **6** REGIONAL HQS



CUSTOMER SUPPORT AND SERVICES

WE'RE THERE FOR YOU WHENEVER YOU NEED US.

We help our customers operate at maximum efficiency by providing them with a range of tried, tested and trusted services - from pre-sales consultancy to post-sales support.



FIELD SERVICES

- On-site service
- Machine installation and testing
- Scheduled preventive maintenance
- Machine repair service



PARTS SUPPLY

- Supplying a wide range of original DN Solutions spare parts
- Parts repair service



TRAINING

- Programming, machine setup and operation
- Electrical and mechanical maintenance
- Applications engineering



TECHNICAL SUPPORT

- Supports machining methods and technology
- Responds to technical queries
- Provides technical consultancy

**Head Office**

19F, 10, Tongil-ro, Jung-gu, Seoul,
Republic of Korea, 04527

Tel: +82-2-6972-0370
Fax: +82-2-6972-0400

DN Solutions America

360 E State PKWY,
Schaumburg, IL. 60173,
United states

Tel: +1-315-265-7500

DN Solutions Europe

Emdener Strasse 24, D-41540
Dormagen, Germany

Tel: +49-2133-5067-100
Fax: +49-2133-5067-111

DN Solutions India

No.82, Jakkuar Village
Yelahanka Hobil,
Bangalore-560064

Tel: +91-80-2205-6900
E-mail: india@dncompany.com

DN Solutions China

Room 101,201,301,
Building 39 Xinzhuan Highway
No.258 Songjiang District
China Shanghai (201612)

Tel: +86 21-5445-1155
Fax: +86 21-6405-1472

DN Solutions Vietnam

M.O.R.E building 2F, 40A-40B Ut
Tich Street, 04 Ward 04,
District Tan Binh District,
Ho Chi Minh City, Vietnam
Tel: +84 28-7304-0163

DN Solutions Mexico

Avenida Parque Bicentenario
#100 Nave M65L3-6,
Fraccionamiento San Isidro
Business Park,
Santa Rosa Jauregui,
Querétaro, México

E-mail: efrain.figueroa@dncompany.com

Sales inquiry

sales@dncompany.com