

Ø400mm COMPACT 5-AXIS MACHINING CENTER

DVF 4000



DVF 4000

Newly added 5-axis model, DVF 4000 has significantly improved reliability and productivity for high speed 5-axis machining. And grease lubrication is applied on X/Y/Z-axis as standard for eco-friendly and cost-saving operation. A stable structure and compact footprint is ideal for the production of small and medium size workpieces with complex shapes.

From small high precision medical parts to small & medium-sized automobile, aerospace and semiconductor parts, it is possible to cover various applications for both AL die-cast high-speed light cutting and titanium, inconel, CoCr difficult-to-cut machining with DVF's high rigidity, high speed spindle and solid column structure table.

CONTENTS

Product Overview

Basic Information

- 04 Basic Structure
- 05 Spindle
- 06 Magazine

Detailed Information

- 07 Standard / Optional Specifications
- 08 Peripheral Equipment
- 09 AWC
- 10 AWC Dimensions
- 12 CUFOS
- 14 FANUC 31i PLUS
- 16 SINUMERIK ONE
- 17 HEIDENHAIN TNC7
- 18 Power | Torque
- 19 External Dimensions
- 20 Working Range
- 21 Machine Specifications

Customer Support Service

- 22 Why 5-Axis machining
- 23 Customer Support and Services
- 23 Global Network



**HIGH SPEED,
HIGH-PERFORMANCE 5-AXIS**

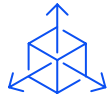

- 12000/15000 r/min direct-coupled high speed spindle
- Ø400 mm rotary tilting table (opt : Ø500mm)
- Max. workpiece weight 200kg
- RGC(Roller Gear Cam) driven type B/C-axis

USER-FRIENDLY MACHINE



- Compact footprint
- Easy operator's access to machine
- Compact automation system (AWC)
- Enhanced chip disposal capability (flushing, chip conveyor)

HIGH PRECISION MACHINING



- Integrated thermal compensation systems for spindle and structure
- Spindle cooling provided as standard
- B/C-axis rotary encoder provided as standard



BASIC STRUCTURE

High precision roller LM guideways on all X/Y/Z-axes promise higher accuracy and structural stability.

Table size

Ø400 mm
(ø15.7 inch)

{Ø500 x 460 OPTION} mm
(ø19.7 x 18.1 inch)

Maximum workpiece size

Ø500 x H480 mm
(ø19.7 x 18.9 inch)

Maximum workpiece weight

200 kg
(440.9 lbs)

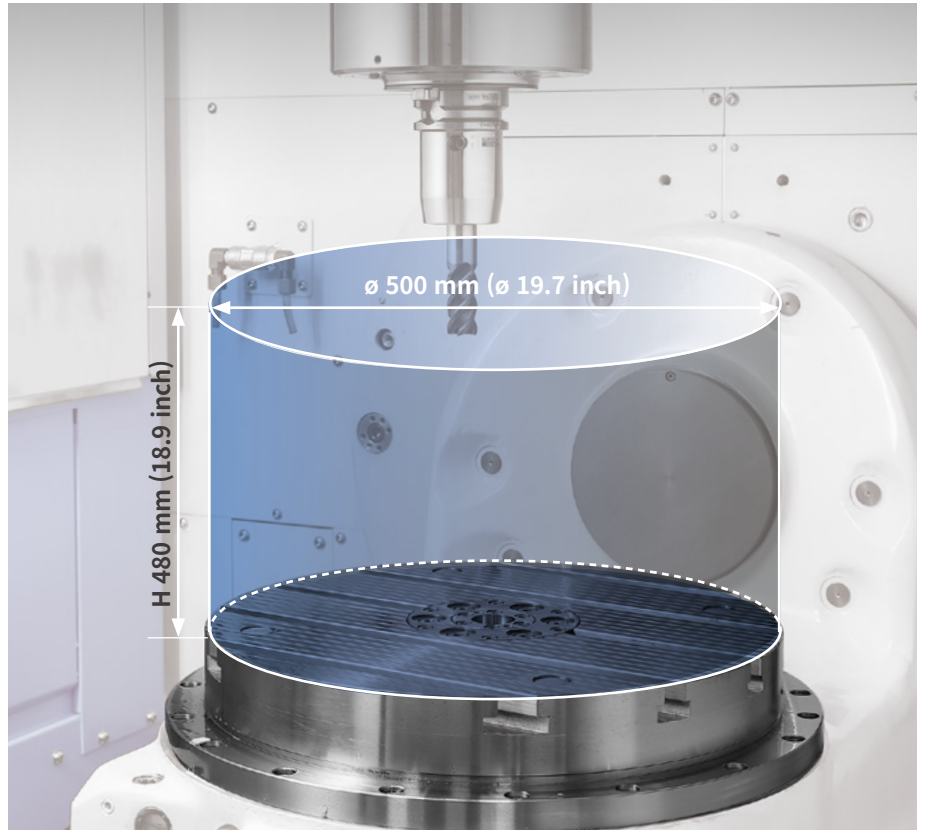

Travel distance

X/Y/Z-axis

620 / 440 / 430 mm
(24.4/17.3/16.9 inch)

Rapid traverse rate

X/Y/Z-axis

36 / 36 / 36 m/min
(1417.3/1417.3/1417.3 ipm)

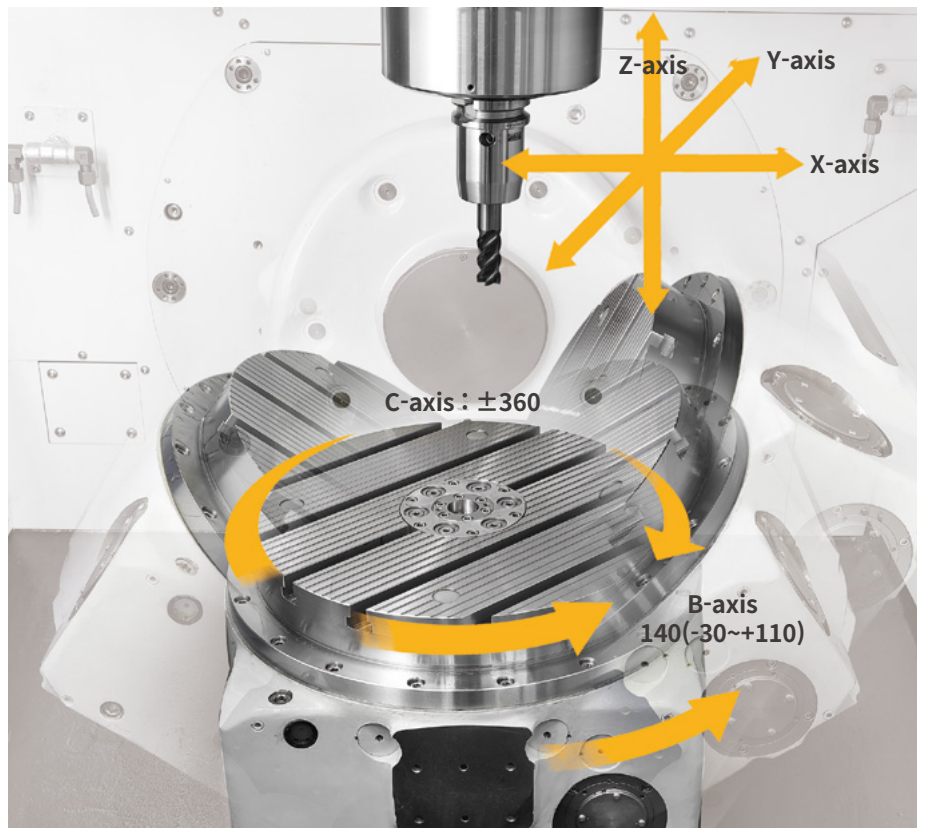

SPINDLE SPECIFICATIONS

Providing stable machining performance with a high-speed, direct-coupled spindle.

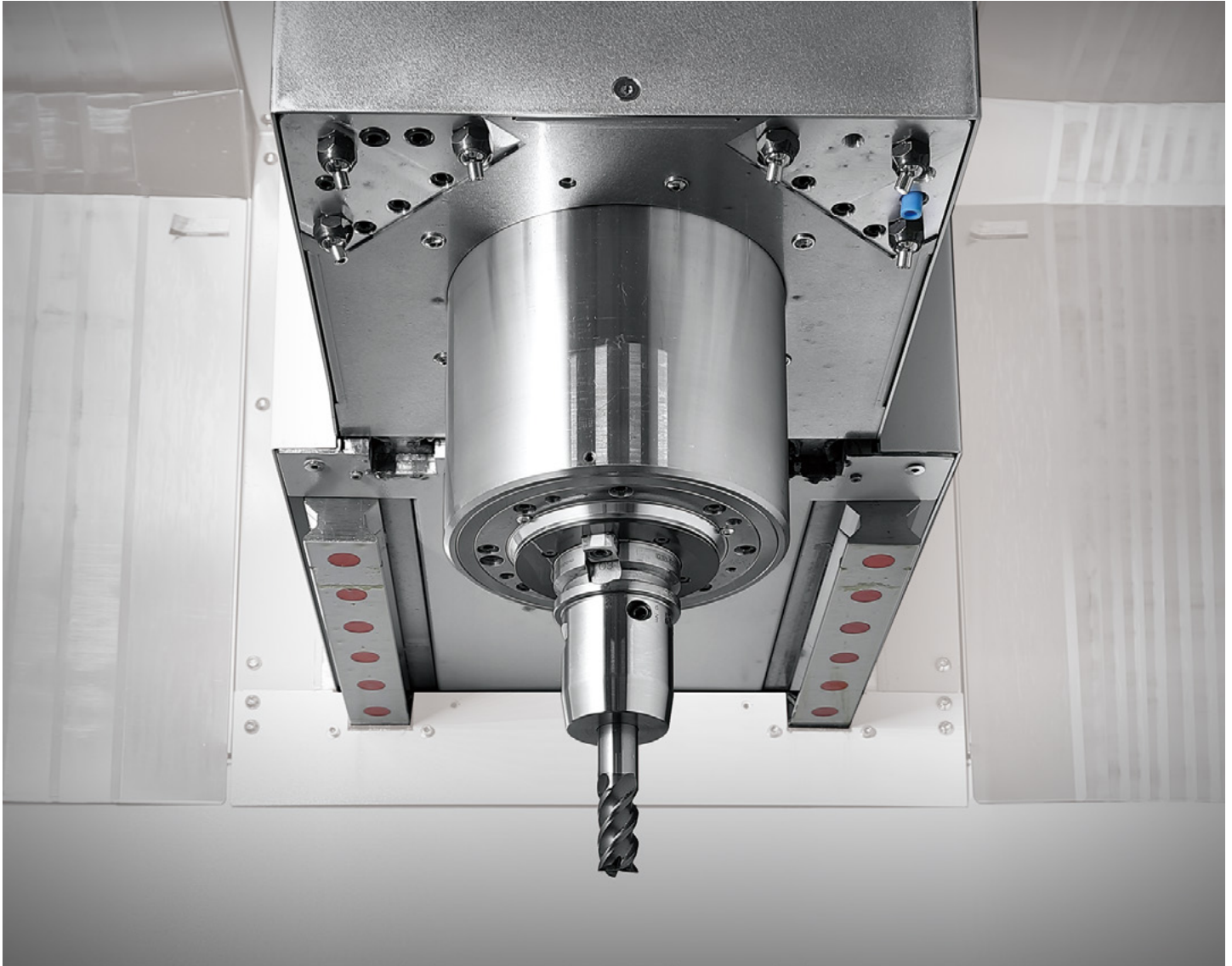

- Oil cooling, spindle smart thermal control as standard
- Tool clamp confirmation sensor

Maximum speed
12000 r/min
 {15000/20000 OPTION} r/min

Maximum power
18.5 kW
 (24.8 hp)

Maximum torque
118 N·m
 (87.1 ft-lbs)

Cover All Possibilities

With cutting-edge technology and an automation-ready framework, this machine elevates your 5-axis capability.

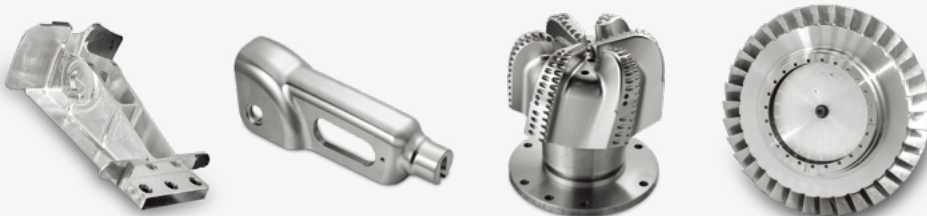

MAGAZINE SPECIFICATIONS

Servo tool magazine delivers high productivity and reliability.

Tool type

ISO #40

Tool capacity

Drum type

30, 40 tools

Chains type

60, 120 tools

Maximum tool diameter

Continuous

75 mm
(3.0 inch)

W/O Adjacent tools

125 mm
(4.9 inch)

Maximum tool length

300 mm
(11.8 inch)

Maximum tool weight

8 kg
(17.6 lb)

Tool-to-tool

T-T-T

1.3 second

C-T-C

4.8 second

30/40 tools



60 tools



120 tools



STANDARD | OPTIONAL SPECIFICATIONS

A range of options is available to suit individual requirements.

Description			DVF4000	
Spindle	12000 r/min(Direct-coupled)		●	
	12000 r/min(Built-in)		○	
	15000 r/min(Direct-coupled)		○	
	15000 r/min(Built-in)		○	
	18000 r/min		○	
	20000 r/min		○	
	10000 r/min		○	
Magazine	Tool storage capacity	30 ea	●	
		40 ea	○	
		60 ea	○	
		120 ea	○	
		175 ea	○	
		204 ea	○	
	Multi-Level round	#40	252 ea	○
			300 ea	○
			120 ea	○
			150 ea	○
		#50	210 ea	○
			258 ea	○
				○
				○
Tool type(shank)	BIG-PLUS BT40		○	
	BIG-PLUS BT50		○	
	CAT/DIN40/HSK63		○	
	CAT/DIN50/HSK A100		○	
	HSK T63		○	
	HSK T100		○	
Coolant	FLOOD&FLUSHING	1.8kW,0.2MPa	●	
		2.5kW,0.2MPa	○	
		4.0kW,2.0MPa,Cyclone filter	○	
	TSC	2.9kW,3.0MPa,Cyclone filter	○	
		7.5kW,7.0MPa,Cyclone filter	○	
	OIL SKIMMER		○	
	Coolant level switch		○	
Coolant chiller		○		
Chip disposal	Chip pan		●	
	Chip conveyor	Hinge+scraper belt type/Left side	○	
		Hinge+scraper belt type/Lear side	○	
		Scraper Drum filter type/Left side	○	
		Scraper Drum filter type/Lear side	○	
		Hinged Drum filter type/Lear side	○	
		CCS II / Scraper Drum	○	
		CCS II / Hinge Drum	○	
	Chip bucket	folklift type, 300L	○	
		Rotation type, 300L	○	
	Air blower		○	
	Air gun		○	
	Coolant gun		○	
	Paper filter		○	
Mist collector	Water soluble	○		
	None water soluble	○		
Rotary table	Air clamping	○		
	Rotary joint	○		
	Fixture interface	B-axis/C-axis	○	
		Hyd. Fixture line thru table center(Max. 4 port)	○	
Accuracy	Structure Smart Thermal Control	Hyd. Fixture line thru table center(Max. 6 port)	○	
		2AB	○	
	2AB+GAP SENSING(5PORT)	○		
Measurement	Structure Smart Thermal Control		○	
	Linear scale		○	
	Rotary encoder		○	
	IKC-READY	Spindle		●
		Structure		●
		X/Y/Z axis		○
		A/B/C axis		○
		S/W ONLY		○
		RENISHAW (RMI-QE)+S/W		○
		HEIDENHAIN(SE660)+S/W		○
	BLUM(RC66)+S/W		○	
	Auto tool length measurement	Touch type	NONE	○
			RTS RENISHAW	○
			TT460 HEIDENHAIN	○
Laser type		ZX SPEED BLUM	○	
		NC4F RENISHAW	○	
		LC50 BLUM	○	
HYBRID	NC4F HYBRID RENISHAW	○		
	LC52 BLUM	○		
Auto workpiece measurement	NONE		●	
	RMP60 RENISHAW		○	
	RMP600 RENISHAW		○	
	TS460 HEIDENHAIN		○	
	TC60 BLUM		○	
DATUM BALL FOR IKC	NONE		●	
	DATUM BALL D25		○	
MASTER TOOL	NONE		●	
	MASTER TOOL		○	
	SINGLE LEVEL AWC		○	
	MULTI LEVEL AWC		○	
Others	APC		○	
	RPS		○	
	LPS		○	
	AUTO DOOR		○	
	LED work light		○	
	Signal tower		○	
Option	Electric cabinet cooling	Fan cooler	○(FANUC) ●(HEIDNEHAIN,SIEMENS)	
		A/C(Air Conditioner)	○	
	EZ WORK		○	
	EZ GUIDE 1		○	
	Automatic power off		○	
	Tool load monitor		○	
	BK9		○	
	SPIN WINDOW		○	
	TSC		○	

* Please contact your DN Solutions representative for detailed machine information.

* When using a semi-synthetic type or synthetic type, contact our sales representative or service center in advance.

● Standard ○ Optional X N/A

 **Fire Safety Precautions** | There is a high risk of fire when using non-water-soluble cutting fluids, processing flammable materials, neglecting the controlled and careful use of coolants and modifying the machine without the consent of the manufacturer. Always check the SAFETY GUIDELINES carefully before using the machine.

PERIPHERAL EQUIPMENT

Automatic Workpiece Measurement

Automatic Tool Measurement



Touch probe : RMP60(Renishaw), TC-60(Blum)

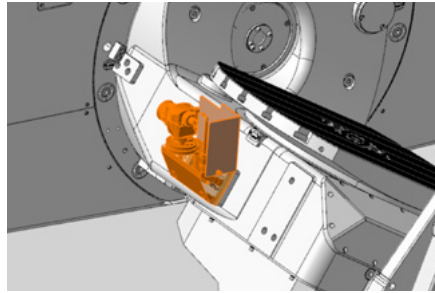

Renishaw(RTS)

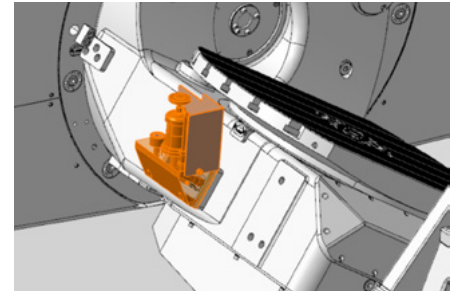

Heidenhain(TT460)

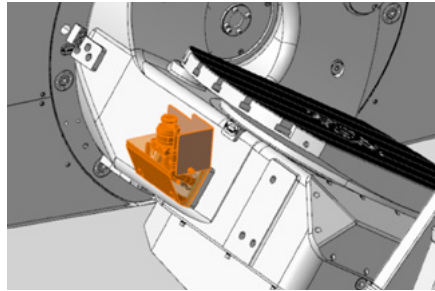

Blum(ZX Speed)

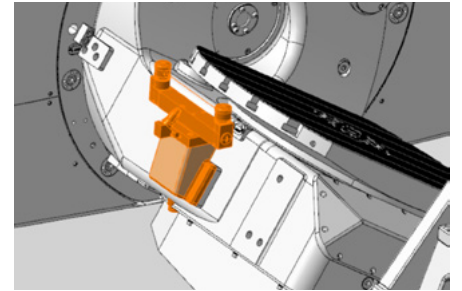

Renishaw(NC4F)

Intelligent Kinematic Compensation for 5-axis

For high-accuracy 5-axis machining, the Intelligent Kinematic Compensation function is recommended. This function minimizes errors in complex 5-axis machining applications by maintaining the tool point in the correct position relative to the workpiece.

In order to use this function, the following optional items are required :

Software

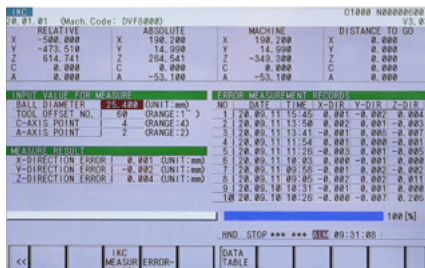

FANUC NC : IKC

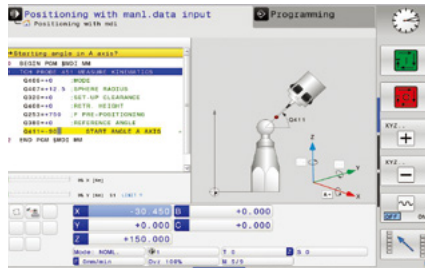

HEIDENHAIN NC : IKC

Receiver Recommended Option



Touch Probe Recommended Option



Datum Ball 선택 (추천)



Auto tool Measurement Recommended Option



Master Tool Recommended Option



AWC

A compact loading/unloading automation capable of mounting up to 40 workpieces.

AWC

A compact automation system providing fast, reliable and high productivity workpiece change capabilities.



Multi-AWC

Automation solution capable of mounting up to 40 workpieces.

Description	Pallet size	No. of pallets	Max. workpiece dia. x height	Max. workpiece weight
AWC	250x250 mm (9.8x9.8 inch)	12ea	Ø300x350 mm (11.8x13.8 inch)	130 kg (286.6 lb)
	350x350 mm (13.8x13.8 inch)	8ea	Ø400x350 mm (15.7x13.8 inch)	300 kg (661.4 lb)
	400x400mm (15.7x15.7 inch)	6ea	Ø450x350 mm (17.7x13.8 inch)	300 kg (661.4 lb)
	500x500mm (19.7x19.7 inch)	4ea	Ø550x350 mm (21.7x13.8 inch)	300 kg (661.4 lb)
Multi-AWC	Ø160 mm (6.3 inch) (HSKA100 Tool Type)	40ea	Ø350x315mm (13.8 x 12.4 inch)	80 kg (176.4 lb)
	250x250mm (9.8x9.8 inch)	40ea	Ø300x350 mm (11.8x13.8 inch)	130 kg (286.6 lb)
	350x350mm (13.8x13.8 inch)	32ea	Ø400x350 mm (15.7x13.8 inch)	300 kg (661.4 lb)
	400x400mm (15.7x15.7 inch)	28ea	Ø450x350 mm (17.7x13.8 inch)	300 kg (661.4 lb)
	500x500mm (19.7x19.7 inch)	24ea	Ø550x350 mm (21.7x13.8 inch)	300 kg (661.4 lb)

Pallet storage-table configuration

unit : mm (inch)

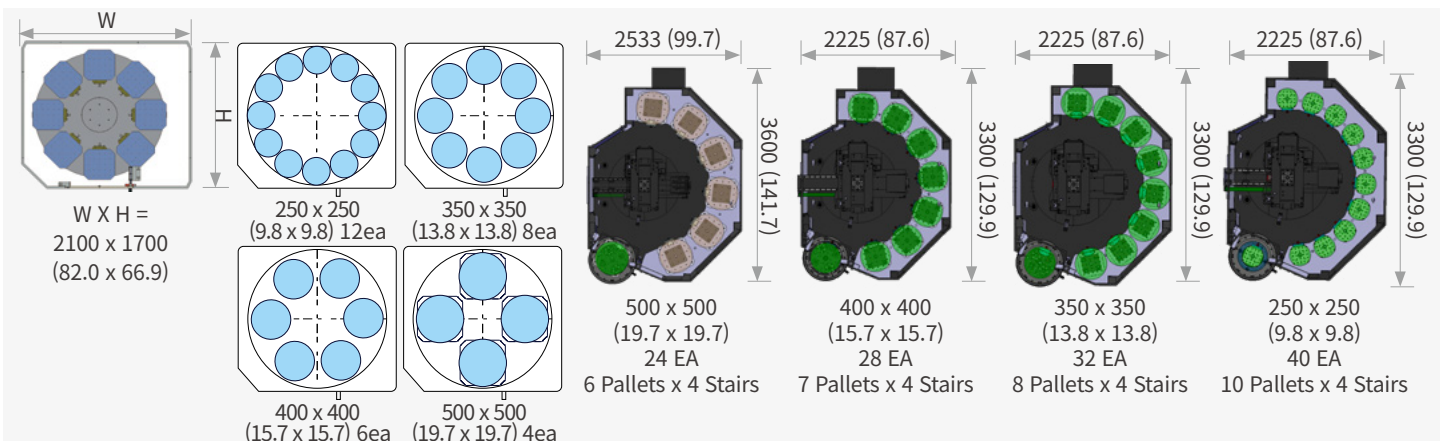

AWC DIMENSIONS

Units : mm (inch)

TOP

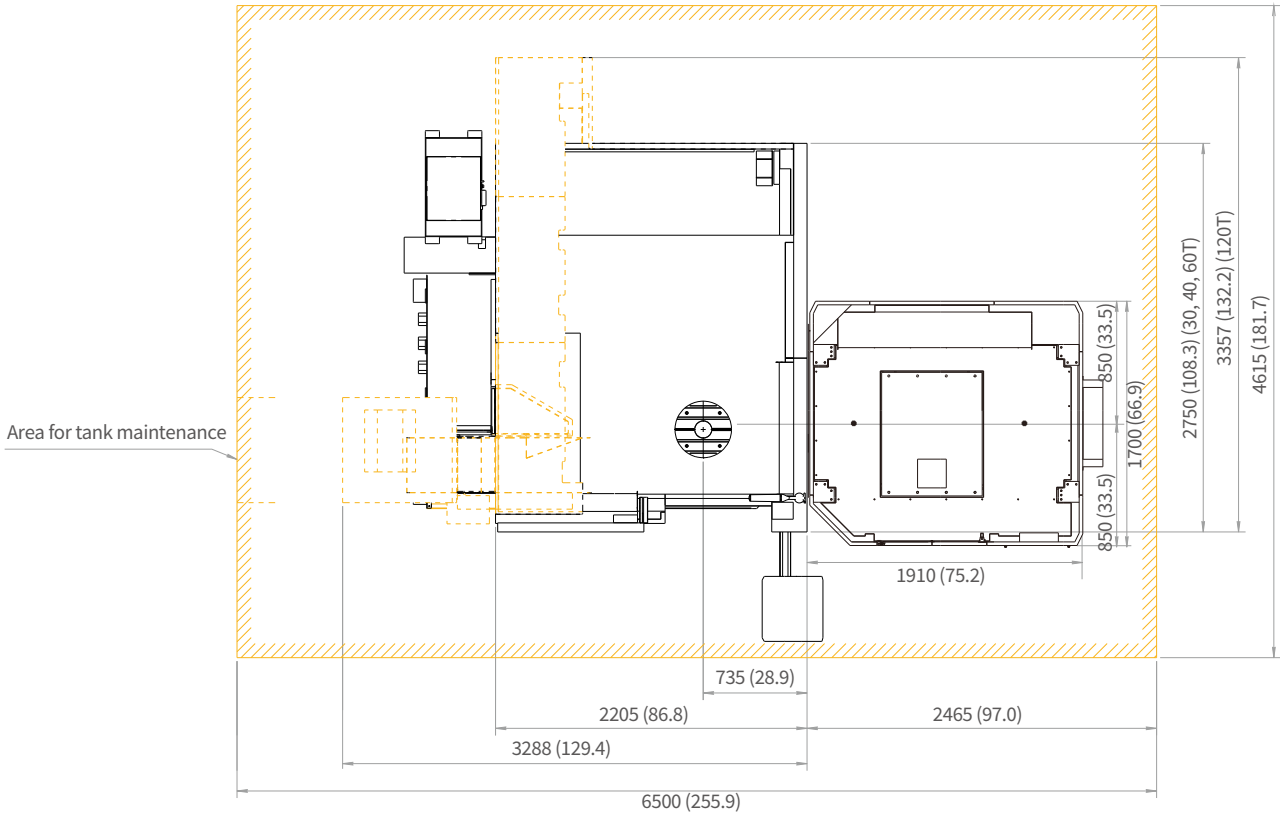

 The area for maintenance

FRONT

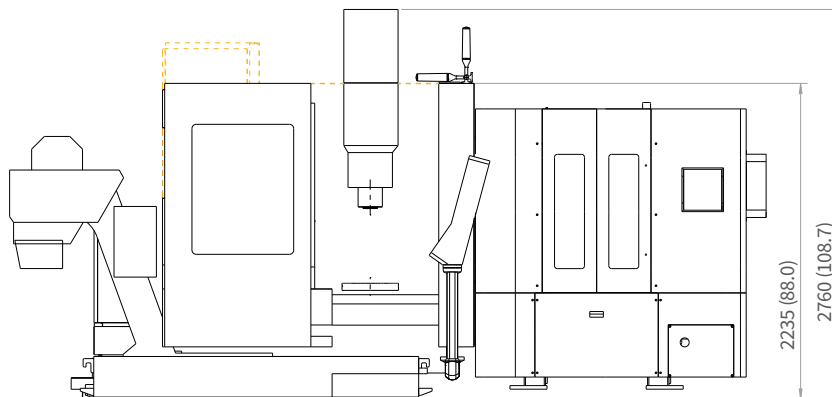

M-AWC DIMENSIONS

Units : mm (inch)

TOP

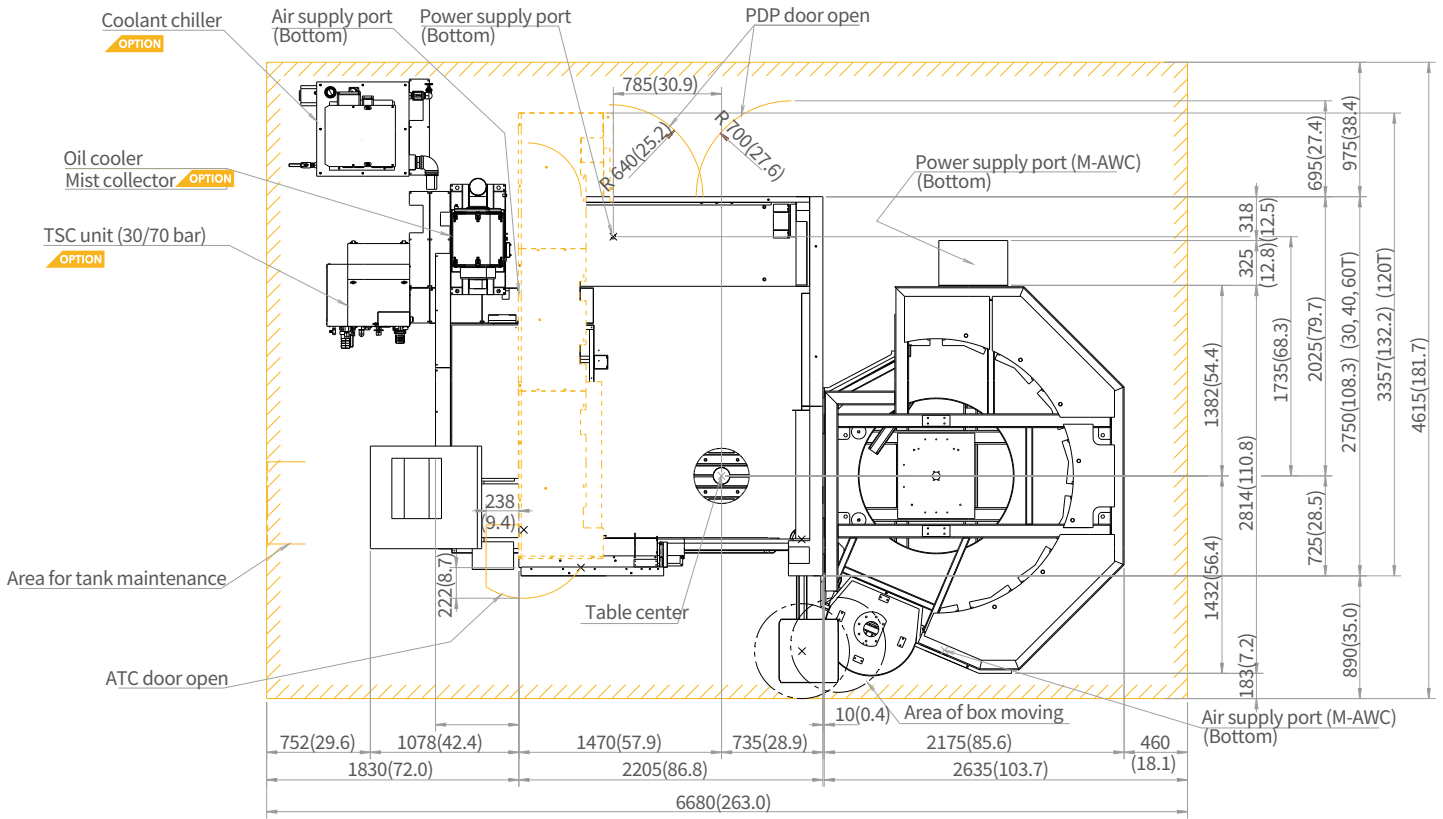

The area for maintenance

FRONT

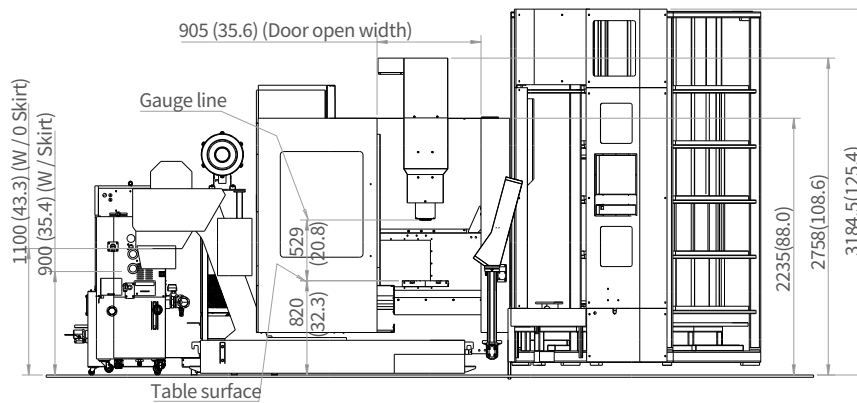

*Some peripheral equipment can be placed in other areas.

CUSTOMIZED USER-FRIENDLY FLEXIBLE OPERATION SOLUTIONS

CUFOS is a PC based control system created by DN Solutions. equipped with intuitive user-friendly functions such as a smart phone screen and easy customization, CUFOS helps to improve operational efficiency and performance for the user.

FEATURES

19 inch TOUCHSCREEN

- Program memory : 40GB
- App-based Interface like smart phone, tablet PC

EASY PROGRAMMING

- Conversational Programming
- SSD data server : Program file sharing/managing (CF card/USB/External PC)

EASY SET-UP/OPERATION

- CPS(collision protection system)
- Manual viewer
- File manager & PDF viewer

EASY MAINTENANCE

- Status monitor
- Alarm guidance
- Maintenance manager
- Easy connection with external S/W (creating additional App.)

CUFOS



CUFOS INTERFACE

User-friendly screen controls

CUFOS, the PC-based control created by DN Solutions, is an integrated system solution using an intuitive 19-inch touchscreen. The system provides a convenient operator interface, a high level of customization and many useful high technology apps.



Supports various apps in three fields—setup, machining and utility

It provides easy configuration by allowing users to add and edit functions on the home screen according to job requirements.

Intuitive operation via touch screen

Simple customization is available for specific work environments



CUFOS Open CNC

CUFOS operation for enhanced productivity

The CUFOS operating system is based upon the integration of all aspects of the manufacturing process, including setting, machining and maintenance. It consolidates up-to-date software technology created by DN Solutions, to improve overall efficiency and productivity. Using the system’s modular construction, each function can be easily integrated with external PC software systems and applications, such as CAM and Tool Data systems.



CUFOS

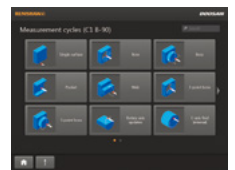
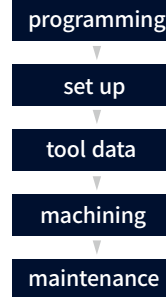

PC software



Applications



Setting

CUFOS provides management and setting functions such as HMI parameter, user setting, setup manager or e-mail. User setting allows users to register and delete up to six users from the account. CUFOS apps and NC functions can be user-restricted as necessary.

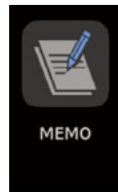

Memo

Users can generate memos, either with a high level of detail via screen capture, or entered by keyboard/touchscreen. The user can add data to existing memos if required. A maximum of 120 memos can be saved



Register up to six user accounts



Screen captures

Memo through touch screen or key board or using a captured screen.

FANUC 31i-B PLUS

FANUC 31i-B Plus maximizes customer productivity and convenience.

15" Touch screen + New OP

DN Solutions Fanuc 31iB/B5 Plus' operation panel enhances operating convenience by incorporating common-design buttons and layout. It features a Qwerty keyboard for fast and easy data input and operation.

FANUC 31i-B Plus

- 15-inch color display
- Intuitive and user-friendly design

USB and PCMCIA card QWERTY keyboard

- EZ-Guide i standard
- Ergonomic operator panel
- 4MB Memory
- Hot keys
- Enhance AICC BLOCK
- Touch pen provided as standard



iHMI touchscreen

iHMI provides an intuitive interface that uses a touchscreen for quick and easy operation.

Range of applications

Providing various applications related to planning, machining, improvement and utility, for customer convenience.



NUMERIC CONTROL SPECIFICATIONS



Description		Features	F31iB5 Plus
			DVF Series
Controlled axis	Controlled axes		5 (X,Y,Z,C,A) (X,Y,Z,C,B)
	Simultaneously controlled axes		5 axis
	Additional controlled axis	Add 1 Axis (5th Axis)	○
Data input/output	data server		○
	Memory card input/output		●
	USB memory input/output		●
Interface function	Embedded Ethernet		●
	Fast Ethernet		○
	Enhanced embedded ethernet function		●
Operation	DNC operation	Included in RS232C interface.	●
	DNC operation with memory card		●
Program input	Workpiece coordinate system	G52 - G59	●
	Addition of workpiece coordinate system	G54.1 P1 X 48 (48 pairs)	●
	Tool number command		T4 digits
	Tilted working plane indexing command	G68.2 TWP	●
Feed function	AI contour control II	G5.1 Q_, 1000 Blocks	●
	High smooth TCP		●
Operation Guidance Function	EZ Guide i		●
	iHMI with machining cycle	Note *1) Only with 15" Touch LCD standard	*
	EZ Operation package		●
Setting and display	CNC screen dual display function		●
Network	FANUC MTConnect		⊕
	FANUC OPC UA		⊕
Others	Display unit	15" color LCD with Touch Panel	●
		10240M(4MB)_1000 programs	●
		20480M(8MB)_1000 programs	○
		2560M(1MB)_2000 programs	○
		5120M(2MB)_4000 programs	○
		10240M(4MB)_4000 programs	○
20480M(8MB)_4000 programs	○		

CONVENIENT OPERATION

FANUC 31i-B Plus

EZ WORK function

Tool load monitoring, Setup guide, Status monitoring, Operation and Recovery guide can provide more convenience and efficiency increasing for user operation.



Thermal Compensation

A function to maintain high-precision machining quality by analyzing and correcting the amount of thermal displacement of a structure through a temperature sensor



M/G-Code List

Functional description of M code and G code

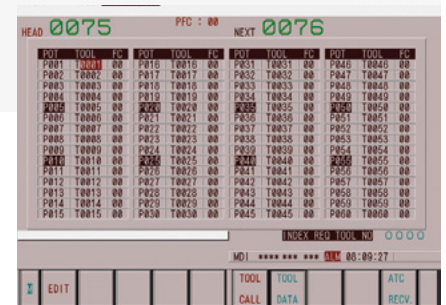

Tool Management

Function to manage tool information [Tool information / Tool No. / Tool condition (normal, large diameter, worn / damaged, used for therst time, manual) / Tool name]



Operation Rate

Machine operation history management function by date based on load

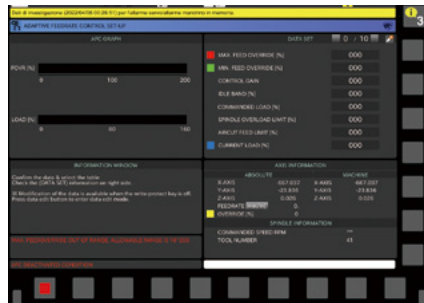

Adaptive Feed Control

Function to control feedrate so that the cutting can be carried out at a constant load

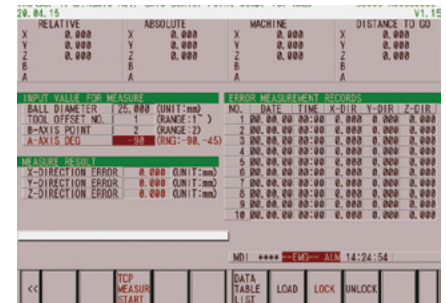

IKC (DCP-I)

The function to compensate the position of the workpiece and the tool tip to be constant regardless of the rotation of the rotating shaft error

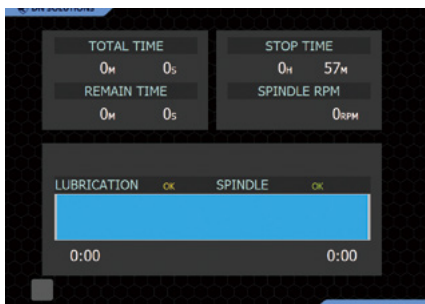

Spindle Warm Up

A function that assists spindle warm-up for spindle life when the spindle has not been used for a certain period of time



ATC Recovery

Function to view detailed info with recommended actions and to perform step-by-step operation manually (when an alarm is triggered during an ATC operation)

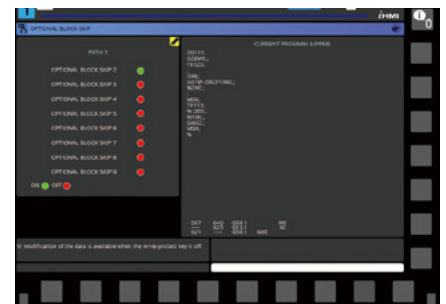

Addition of Optional Block Skip

In addition to the OPTIONAL BLOCK SKIP of the operation panel, the function to skip a specific block selected in the machining program

CONVENIENT OPERATION

SIEMENS SINUMERIK ONE

Even Faster & Easier processing + 21.5" screen

All programming, set-up, actual machining and verification process are getting easier and faster. Especially, intuitive conversational programming guidance with 3D UI(user interface) on 21.5" large touch screen is helpful for unskilled engineers.

- 21.5 inch touch screen
- 50% improvement in processing speed (compared to S840D)
- Graphic programming
- PLC-based flexible automation/peripheral device expandability



Conversational convenient function

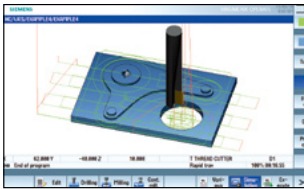

Simulation and machining contour monitoring

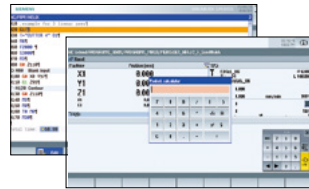

Smart function

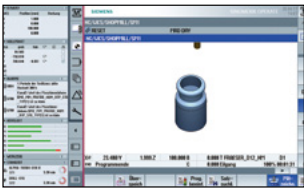

Side screen widget

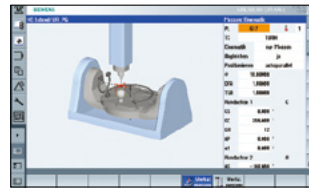

5-axis kinematic measuring cycles

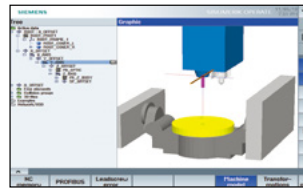

3D collision avoidance and collision avoidance ECO

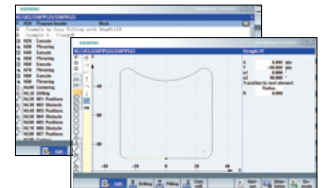

Shop mill part programming

NUMERIC CONTROL SPECIFICATIONS

SIEMENS

Item	Specifications	S-ONE
Controlled axis	Controlled axes	5 axes (X,Y,Z,C,B)
	Simultaneously controlled axes	5 axes
Data input/output	Memory card input/output	●
	USB memory input/output	●
Interface function	Ethernet	●
	Execution from External Storage(EES)	(X130)
Operation	On network drive	○
	On USB storage medium, e.g. memory stick	●
Program input	Workpiece coordinate system	●
	Addition of workpiece coordinate system	●
	Top surface	○
Interpolation & Feed function	Look ahead number of block monitoring for max. tool speed/ acceleration	1000
	Top Surface	○
	Top Speed Plus	○
Programming & Editing function	3D simulation, finished part	●
	Simultaneous recording	●
	Measure kinematics	●
	DXF Reader for PC integrated in SINUMERIK Operate	○
Operation Guidance Function	ShopMill	●
	EZ Work	●
Setting and display	Operation via a VNC viewer	●
Network	MTConnect	●
	OPCUA	⊕
	18.5" color display with touch screen	○
	21.5" color display with touch screen	●
Others	CNC user memory	●
	Max. CNC user memory	10 MB
	Collision avoidance (machine, working area)	○
	Collision avoidance ECO (machine, working area)	●
	Evaluation of internal drive	○
	CNC user memory extend	○
	TOOL ID	○
	PMM	○

CONVENIENT OPERATION

HEIDENHAIN TNC7

Visualized, intuitive task support, customized UI

The TNC7 makes machining even easier, for everything from programming to program validation and from machine setup to actual machining. You intuitively operate highly complex applications directly on the touchscreen with various integrated solutions for standard tasks.

TNC7 NEW

- 24 inch touch screen
- 89GB Program memory
- Look-ahead 5000 blocks
- Touch Probe Cycles Graphical Programming



<TNC7>

Conversational convenient function

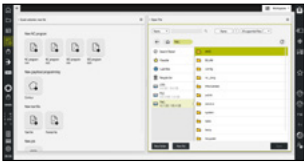

Data are controlled in the folder structure; convenient communication via USB devices

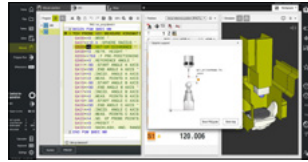

KinematicOpt & KinematicComp (Touch probe cycle for automatic measurement) OPTION

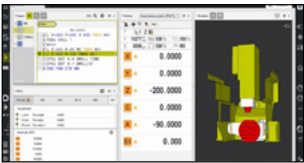

Collision protection system OPTION



Graphic simulation

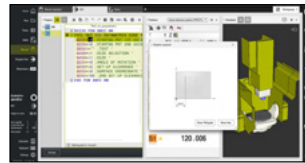

Various built-in pattern cycles for a wider scope of application (Software standard) OPTION



Enhanced collision protection function DCMv2 OPTION



Improved maintenance environment



Highly practical programming and setup based on touch operation

NUMERIC CONTROL SPECIFICATIONS



HEIDENHAIN

Item	Specifications	TNC7
Controlled axis	Controlled axis	5 axes (X,Y,Z,C,B)
	Simultaneously controlled axis	5 axes
Interface function	Embedded ethernet	●
	USB interface (USB 2.0)	●
	HEIDENHAIN DNC	○
Feed function	Look-ahead	5000 blocks
	Adaptive Feed Control	●
Axis compensation	KinematicsOpt	Automatic measurement and optimization of machine kinematics
Collision monitoring	Dynamic collision monitoring (DCM)	○
	Dynamic Collision Monitoring v2	○
Network	MT Connect	⊕
	Display unit	touch panel
Others	Program memory for NC programs	189GB
	CAD Import	○
	Ext. Tool Management	○
	Active Chatter Control	○
	Model Aided Setup	○
	Opt. Contour Milling	○
	Process Monitoring	○

POWER | TORQUE

Built_in

FANUC_12000 r/min

Max. spindle power

22 / 18.5 kW (29.5 / 24.8 Hp)

Max. Spindle torque

204.23 N·m (150.7 ft-lbs)

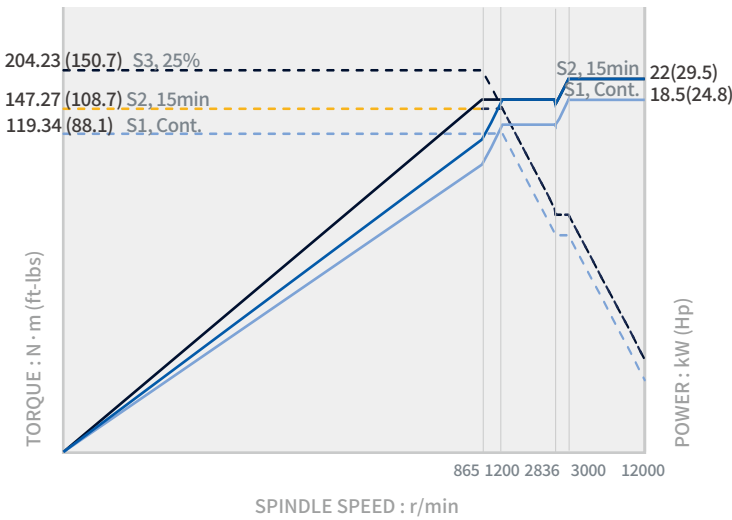

FANUC_18000 r/min

Max. spindle power

22 / 18.5 kW (29.5 / 24.8 Hp)

Max. Spindle torque

117.77 N·m (86.9 ft-lbs)

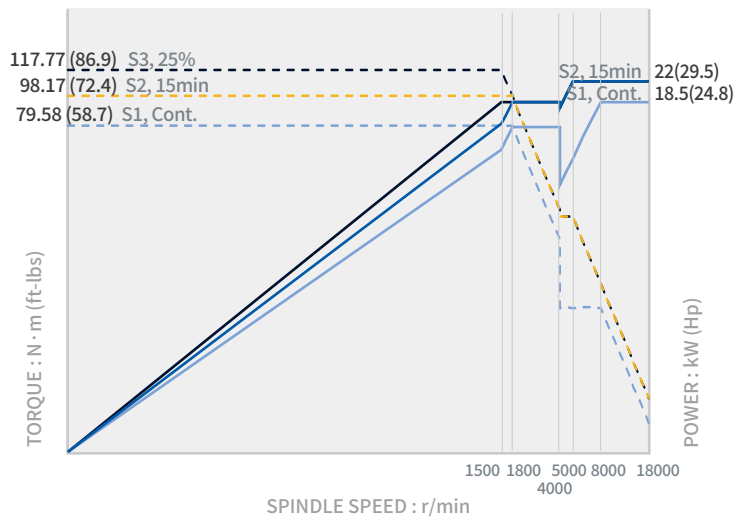

SIEMENS

Max. spindle power

30 / 24 kW (40.2 / 32.2 Hp)

Max. Spindle torque

155 N·m (114.4 ft-lbs)

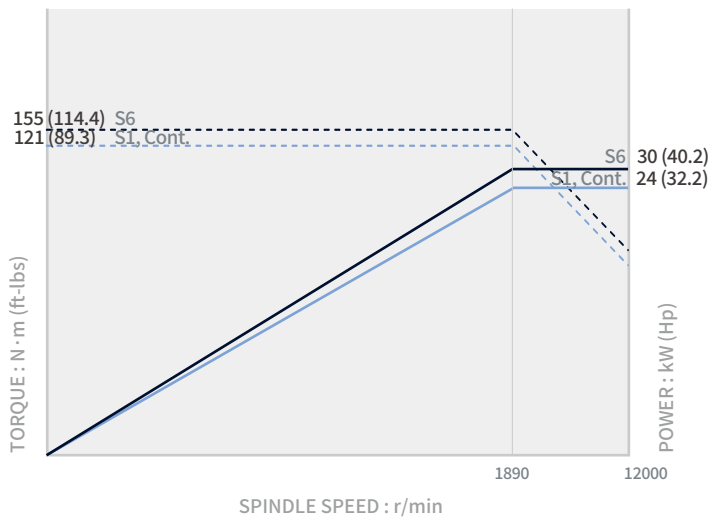

HEIDENHAIN

Max. spindle power

30 / 24 kW (40.2 / 32.2 Hp)

Max. Spindle torque

155 N·m (114.4 ft-lbs)

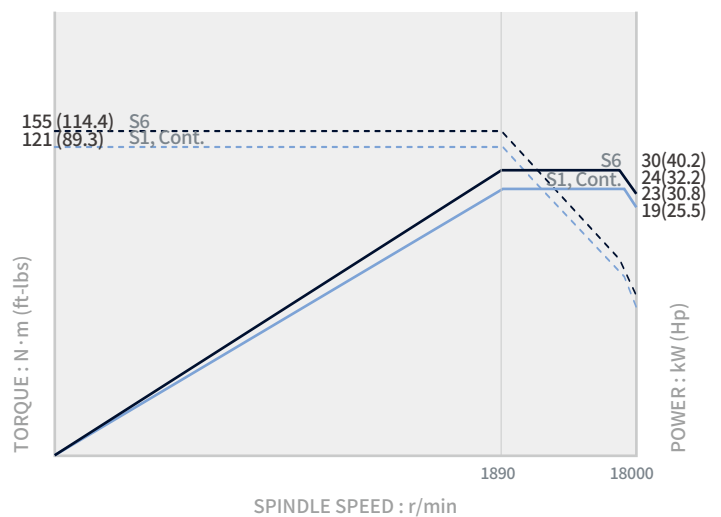

EXTERNAL DIMENSIONS

Units : mm (inch)

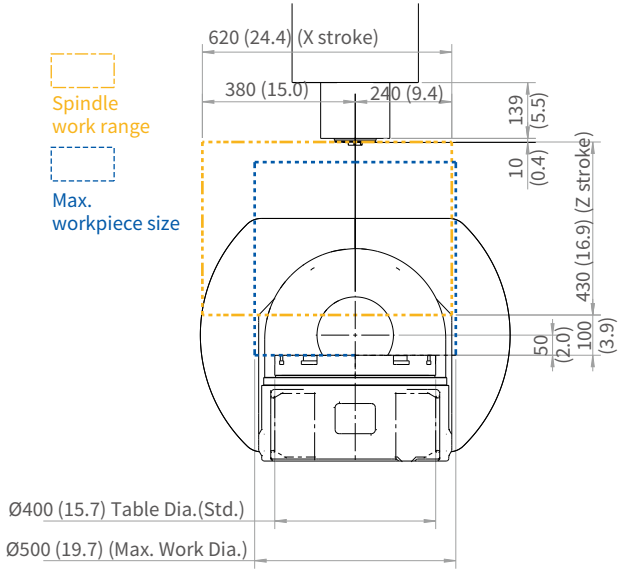

HSK 100T type

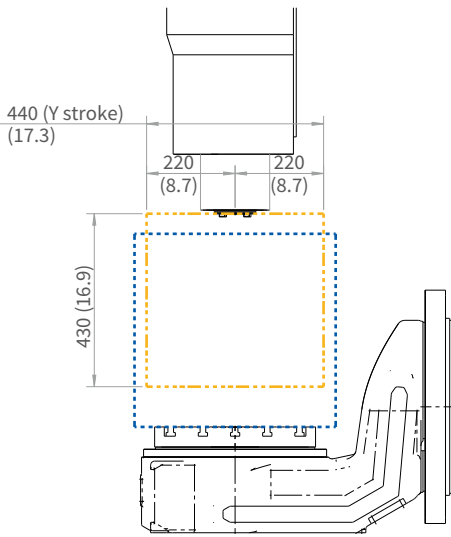
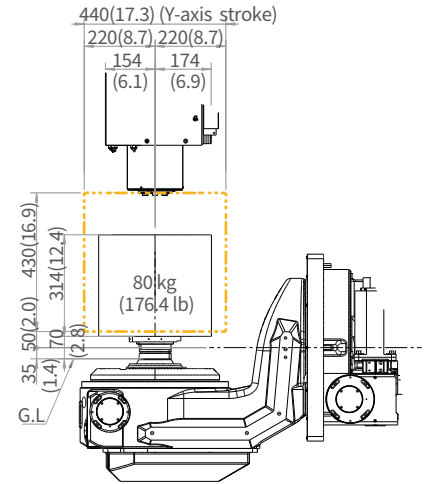
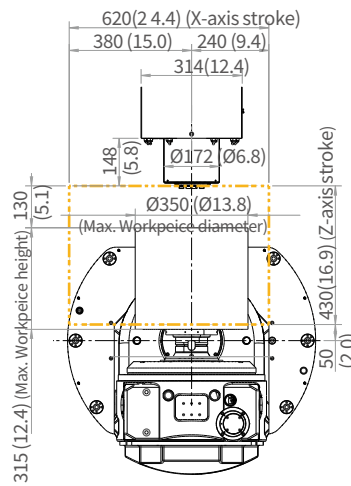

Pallet type_8 AWC

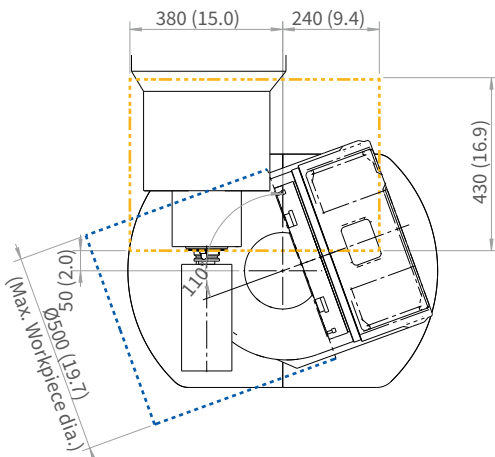
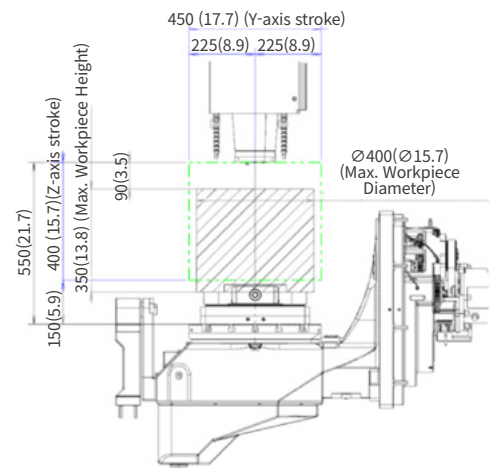
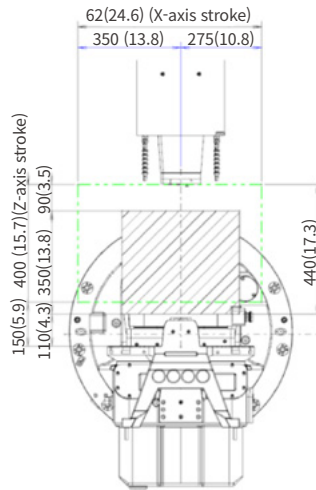

MACHINE SPECIFICATIONS

Description		Unit	DVF 4000	
Travels	Travel distance	X axis	mm (inch)	620 (24.4)
		Y axis	mm (inch)	440 (17.3)
		Z axis	mm (inch)	430 (16.9)
		B axis	deg	140 (-30~+110)
		C axis	deg	360
Table	Table size		mm (inch)	Ø400 {Ø500 x 460} (Ø15.7 {Ø19.7 x 18.1})
	Max. workpiece size		mm (inch)	Ø500 X H480 (Ø19.7 X H18.9)
	Table loading capacity		kg (lb)	200 (440.9)
Spindle	Max. spindle speed		r/min	20000
	Max. spindle power		kW (Hp)	18.5/11 (S3 15%/Cont) (24.8/14.8)
	Max. spindle torque		N·m (ft-lbs)	118 (87.1)
Feedrate	Rapid traverse rate	X axis	m/min (ipm)	36 (1417.3)
		Y axis	m/min (ipm)	36 (1417.3)
		Z axis	m/min (ipm)	36 (1417.3)
		B axis	r/min	20
		C axis	r/min	20
Automatic tool changer	Type of tool shank		-	ISO #40
	Tool storage capa.		ea	30 {40, 60, 120}
	Max. tool diameter	Continuous	mm (inch)	75 (3.0)
		Without adjacent tools	mm (inch)	125 (4.9)
	Max. tool length		mm (inch)	300 (11.8)
	Max. tool weight		kg (lb)	8 (17.6)
	Tool change (T-T-T)		sec	1.3 (60Hz)
	Tool change time (C-T-C)		sec	4.6 (60Hz)
Tank capacity	Coolant tank capacity		L (gal)	485 (128.1)
Machine dimensions	Height		mm (inch)	2760 (108.7)
	Length x Width		mm (inch)	2750 x 2205 (108.3 x 86.8)
	Width		kg (lb)	7500 (16534.4)
Control	NC system		-	DN Solutions Fanuc i Plus / Fanuc 31iB5 Plus/ Heidenhain, FANUC, Siemens

WHY 5-Axis machining?

SINGLE SETUP EFFICIENCY

5-axis machining allows you to approach the workpiece from all angles, with complete access to five sides of the part in a single setup. This reduces the overall number of part setups compared to traditional machining, which minimizes machine downtime and maximizes chip making time.



IMPROVED PART ACCURACY

When making parts with multi-sided features using traditional 3-axis machining, multiple part setups are required. This means new inaccuracies can arise each time the workpiece is repositioned. 5-axis machining eliminates stacked tolerances and improves overall part dimensional accuracy.

EXTENDED MACHINE SHOP CAPABILITY

DN Solutions 5-axis machines open up new doors for your machine shop. The increased efficiency will make you instantly more competitive, and full 5-axis machining capabilities give you the opportunity to quote on jobs that previously weren't possible. So, what are you going to make today?



“Compared with similar machines from Japan or Europe, DN Solutions has the same level of precision and quality at a better value for money.”

- **OMGM Group, Italy**

“Our DN Solutions 5-axis is making complex, high precision parts for aerospace and defense. Cycle times have been reduced dramatically.”

- **Aerotech Precision Manufacturing, Great Britain**

RESPONDING TO CUSTOMERS **ANYTIME, ANYWHERE**

DN SOLUTIONS GLOBAL NETWORK

66 COUNTRIES | **140** + SALES NETWORKS | **3** FACTORIES | **6** REGIONAL HQS



CUSTOMER SUPPORT AND SERVICES

WE'RE THERE FOR YOU WHENEVER YOU NEED US.

We help our customers operate at maximum efficiency by providing them with a range of tried, tested and trusted services - from pre-sales consultancy to post-sales support.



FIELD SERVICES

- On-site service
- Machine installation and testing
- Scheduled preventive maintenance
- Machine repair service



PARTS SUPPLY

- Supplying a wide range of original DN Solutions spare parts
- Parts repair service



TRAINING

- Programming, machine setup and operation
- Electrical and mechanical maintenance
- Applications engineering



TECHNICAL SUPPORT

- Supports machining methods and technology
- Responds to technical queries
- Provides technical consultancy

**Head Office**

19F, 10, Tongil-ro, Jung-gu, Seoul,
Republic of Korea, 04527

Tel: +82-2-6972-0370
Fax: +82-2-6972-0400

DN Solutions America

360 E State PKWY,
Schaumburg, IL. 60173,
United states

Tel: +1-315-265-7500

DN Solutions Europe

Emdener Strasse 24, D-41540
Dormagen, Germany

Tel: +49-2133-5067-100
Fax: +49-2133-5067-111

DN Solutions India

No.82, Jakkur Village
Yelahanka Hobli,
Bangalore-560064

Tel: +91-80-2205-6900
E-mail: india@dncompany.com

DN Solutions China

Room 101,201,301,
Building 39 Xinzhuan Highway
No.258 Songjiang District
China Shanghai (201612)

Tel: +86 21-5445-1155
Fax: +86 21-6405-1472

DN Solutions Vietnam

M.O.R.E building 2F, 40A-40B Ut
Tich Street, 04 Ward 04,
District Tan Binh District,
Ho Chi Minh City, Vietnam

Tel: +84 28-7304-0163

DN Solutions Mexico

Avenida Parque Bicentenario
#100 Nave M65L3-6,
Fraccionamiento San Isidro
Business Park,
Santa Rosa Jauregui,
Querétaro, México

E-mail: efrain.figueroa@dncompany.com

Sales inquiry

sales@dncompany.com