

HIGH-PRECISION, HIGH-SPEED VERTICAL MACHINING CENTER

# MP 6500

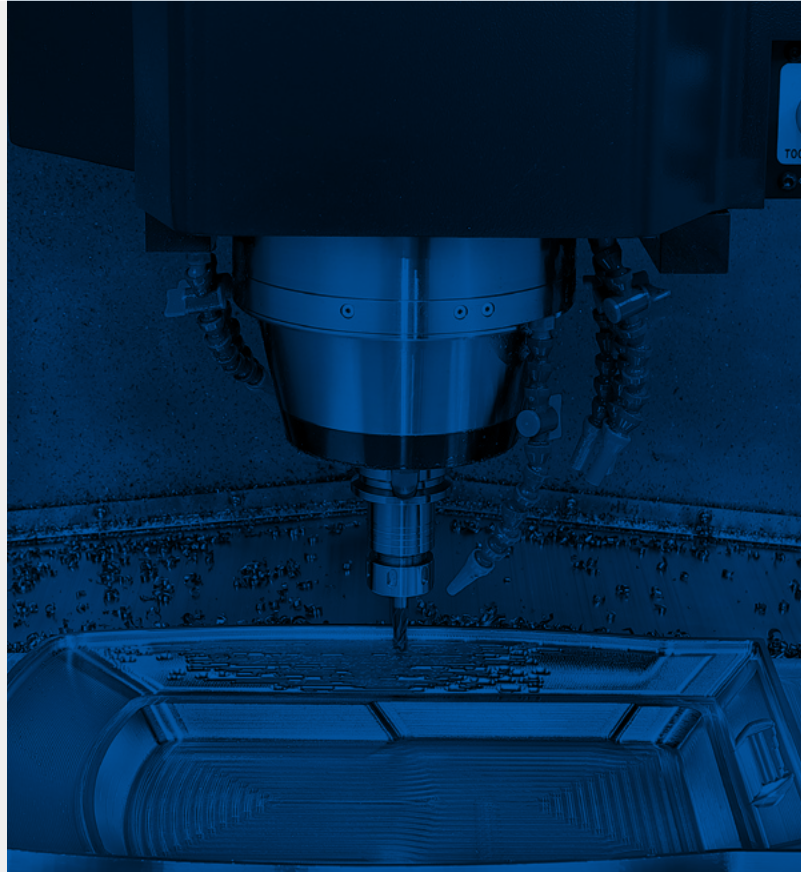

# MP 6500

MP 6500 vertical machining centers are designed with a thermally-symmetrical bridge type structure to optimise precision and workpiece quality. High accuracy is also enhanced by using a constantly pre-loaded high-speed spindle. Operator convenience is improved by optimised accessibility and a range of operator functions.

## CONTENTS

### Product Overview

### Basic Information

- 04** Basic Structure
- 05** Feed System
- 06** Spindle
- 07** Table
- 08** Optimized Tool Processing Solution

### Detailed Information

- 09** Standard | Optional Specifications
- 10** Peripheral Equipment
- 11** Convenience
- 12** Fanuc 31iB Plus
- 13** EZ work
- 14** Convenient Operation
- 16** Power | Torque
- 17** Dimensions
- 18** Table
- 19** Machine Specifications



**IMPROVED SPINDLE  
RIGIDITY AND LIFE**



Improved spindle rigidity in the low speed range and long spindle life with constant pre-loaded spindle in high speed range.

**STABLE BRIDGE TYPE  
STRUCTURE**



Thermal analysis of the machines' symmetrical design and build, and the minimal overhang of the bridge type structure provides the optimal solution for high-speed / high-precision processing.

**OPTIMIZED MOLD  
PROCESSING SOLUTION**



Thermal error compensation system, high speed spindle, high accuracy contour control, and the tool measurement system are provided as standard to improve mold processing performance.

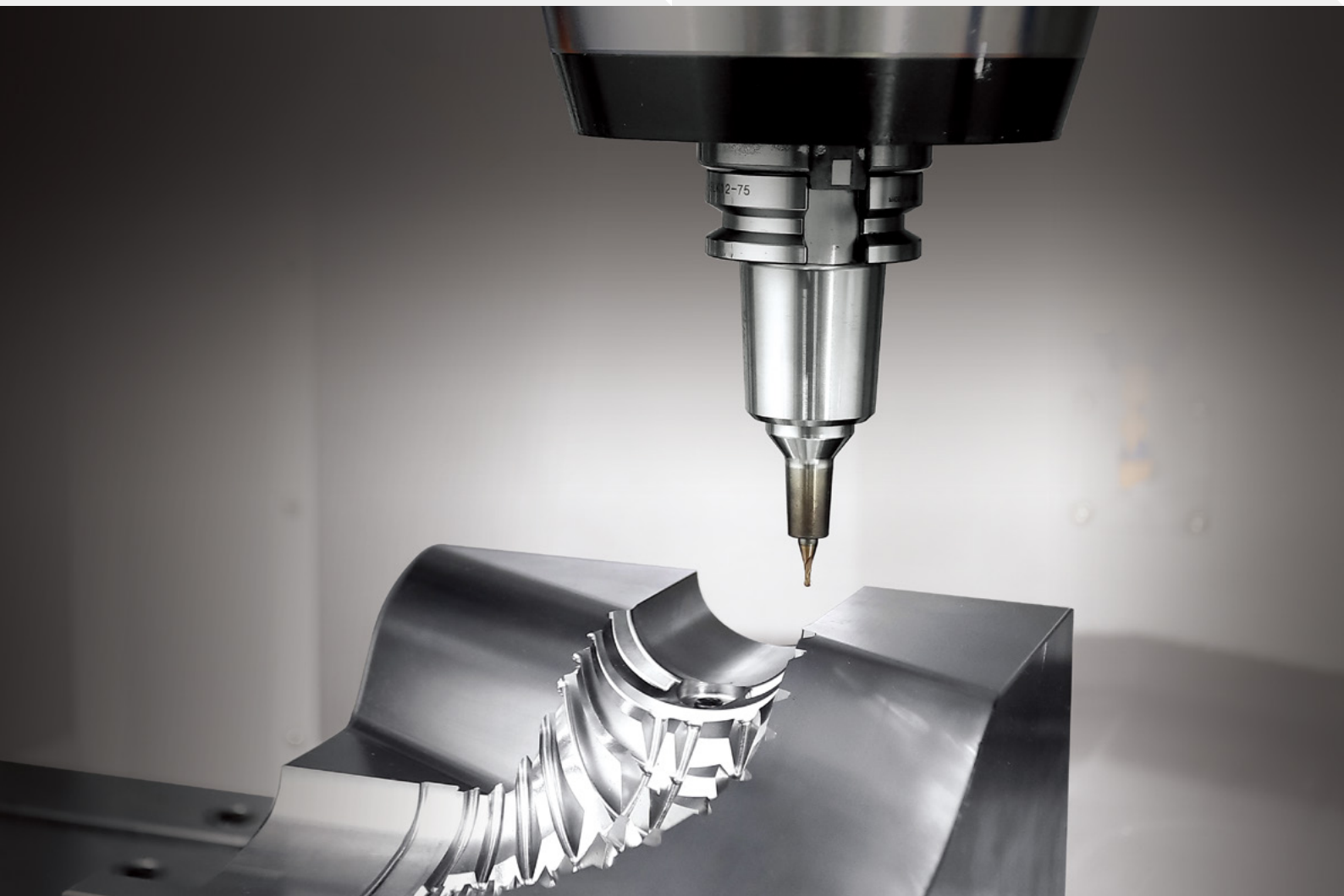

# BASIC STRUCTURE

MP 6500 has a bridge-type structure for high-performance and high-accuracy machining.

## Bridge-type structure

Thermal analysis of the machine's symmetrical structure proves that this is the optimal solution for high precision machining of molds.

Travel distance (X / Y / Z axis)

**1100 / 650 / 550** mm  
(43.3/25.6/21.7 inch)

Rapid traverse rate (X / Y / Z axis)

**30 / 30 / 30** m/min  
(1181.1/1181.1/1181.1 ipm)

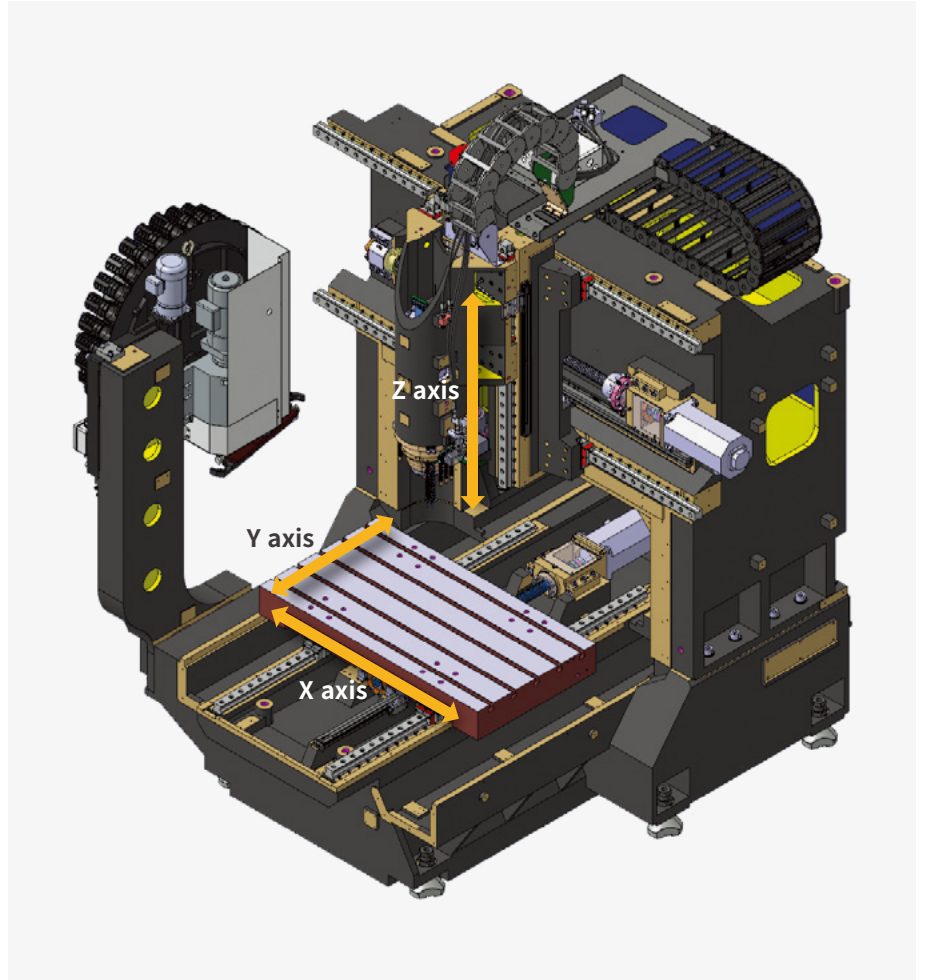

## Gravity center drive structure

By minimizing the distance between the center of gravity and the feed drive center, inertia movement is reduced allowing for faster feed rates and more precise part machining.

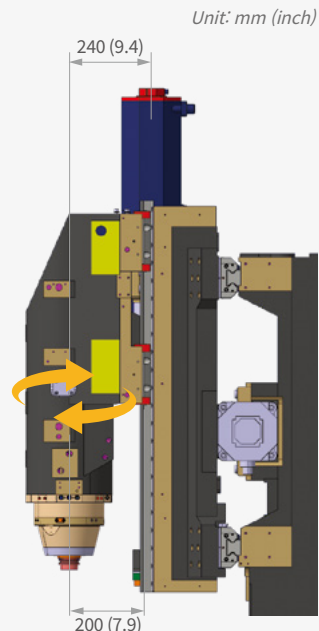

## High precision

Optimization of the machine structure has increased rigidity and reduced stresses and strains.

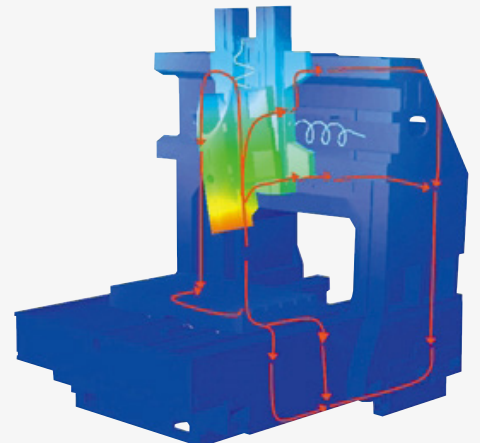

# FEED SYSTEM

The linear axes are equipped with roller linear guideways for increased rigidity and a cooling system supplied as standard to minimize thermal error.

## High-precision travel system

Roller-type linear guideways, high-rigidity coupling and a ball screw nut cooling system achieve high rigidity and outstanding linear axis accuracy of the feed drive system.

**Roller linear guideway**

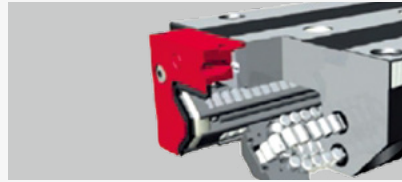

**Rigid coupling**

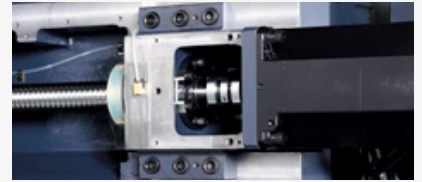

**Ball screw nut cooling**

Reduced thermal displacement of feed shafts Stability and rigidity of the feed system

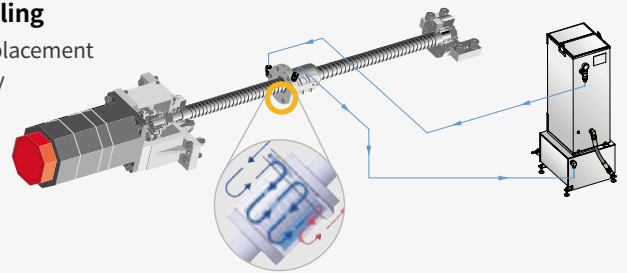

## High power servo motor

The responsiveness of each axis feed system is improved by reducing the load / motor inertia ratio by 50%.

**MP 6500**

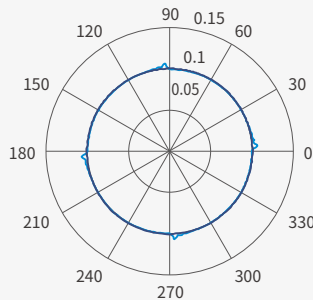

**General processing system**

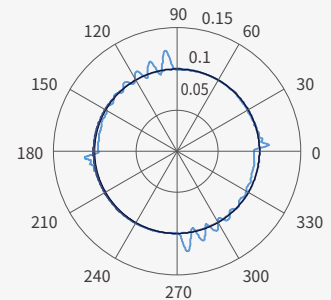

## TOOL CHANGER

Rapid tool change reduces idling time and improves productivity.

**Tool storage capacity**

**30** {40 OPTION} ea

**Tool change time**

**1.6 s**

**Automatic tool changer**

Enhanced productivity achieved with the high speed tool changer.



# SPINDLE

High-precision spindle and excellent dynamic balancing reduces vibration during high-speed machining and ensures high accuracy.

## High-rigidity, high-precision spindle

With its new constant preloading structure, improved spindle rigidity in the low speed range and long spindle life are realised.

### Max. spindle speed

**20000** r/min  
 {15000 / 30000 / 40000 **OPTION**} r/min

### Spindle motor power

**22 / 11** kW  
 (29.5 / 14.8 Hp)

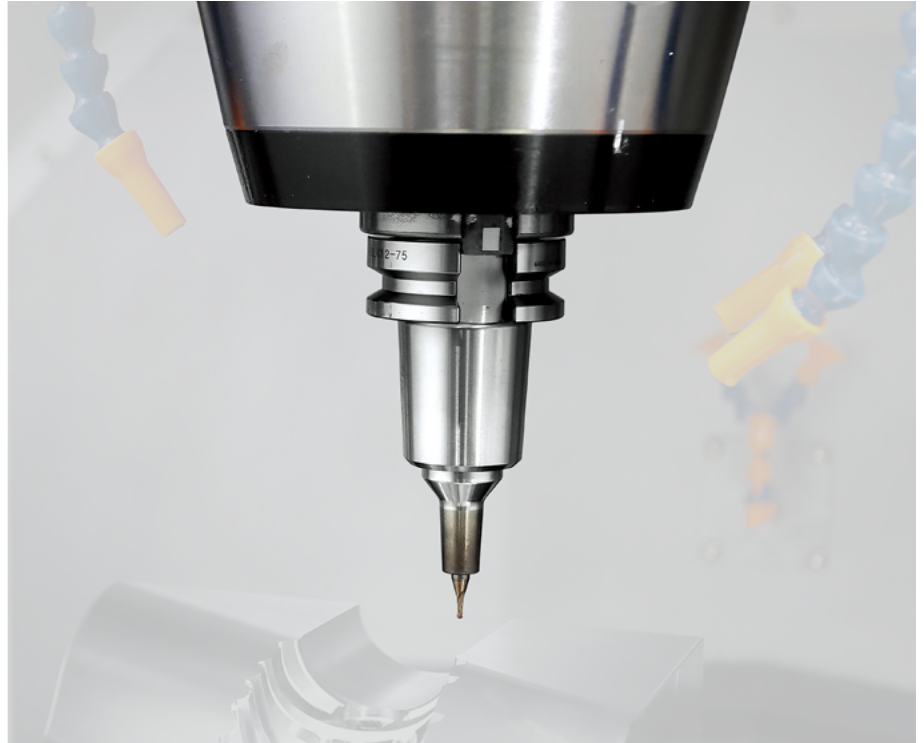

## Spindle type and tool specification

A high-speed spindle, up to 40000 r/min, can be selected according to customers' machining requirements (i.e., workpiece materials and cutting conditions). A dual-contact spindle can be selected to improve surface finishes and to extend tool life.

Item	20000 r/min	15000 r/min <b>OPTION</b>	30000 r/min <b>OPTION</b>	40000 r/min <b>OPTION</b>
<b>Spindle motor power kW (Hp)</b>	22 / 11 (29.5 / 14.8)	37 / 22 (49.6 / 29.5)	18.5 / 13 (24.8 / 17.4)	5.5 / 3.7 (7.4 / 5.0)
<b>Taper spindle</b>	ISO#40	ISO#40	HSK-F63	HSK-E40

## Spindle cooling system

Cooling system removes heat generated at the bearings and motor to minimize thermal error. The air-oil cooling system removes heat generated at the bearings and motor to reduce thermal error and extend machine tool service life.

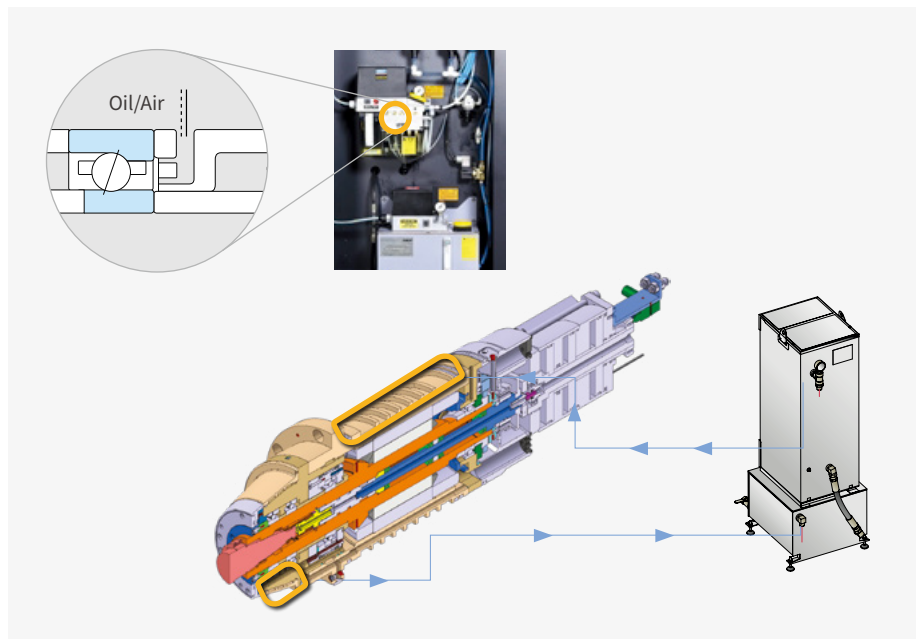

# TABLE

Wide cutting area for machining a diverse range of workpieces.

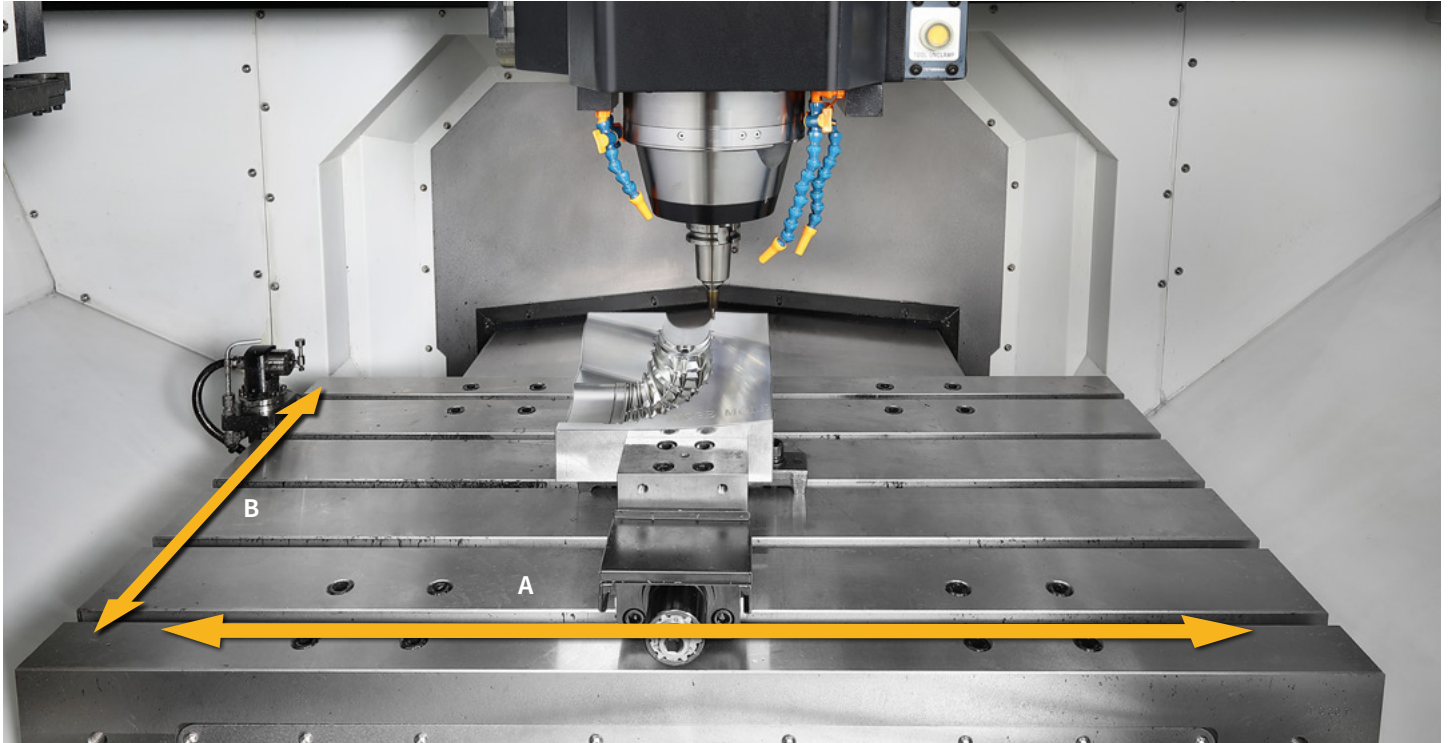

### Wide cutting area

The size and load capacity of the table allow for the setting up and machining of large and diverse-shaped workpieces.

### Table size (A x B)

**1200 x 650** mm  
(47.2 x 25.6 inch)

### Table loading capacity

**800** kg  
(1763.7lb)

### Z-axis fine feeding

Z axis : **0.4** mm Repeat feed  
(0.016 inch)

### Spindle speed

**19000** r/min



Machine		MP 6500
Item		Pattern mold
Material		HP4M
Condition	Tool	F1 Ball Endmill
	Spindle speed / Feed rate	Speed : 19000 r/min, Feed : 800 mm/min (31.5 ipm)
	Time	134 hr

# OPTIMIZED TOOL PROCESSING SOLUTION

Superior surface finishes and superior machining precision are achieved by using standard DN Solutions processing solutions, such as high speed / high precision contour control and thermal displacement compensation functions.

## Tool load monitoring system (DTMM\*)

The technology of protecting tool and machine in abnormal load during the cutting process

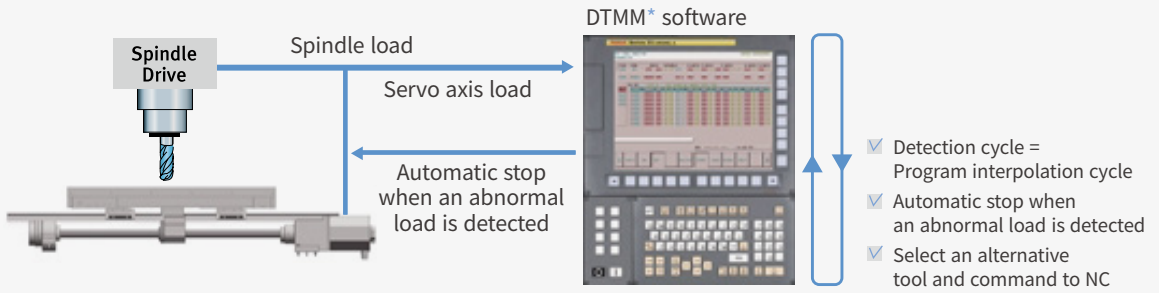

\*DTMM : DN Solutions Tool load Monitoring for Machining Centers

## The optimal feed control (DAFC\*)

Optimal feed control is ensured by realtime spindle load detection.

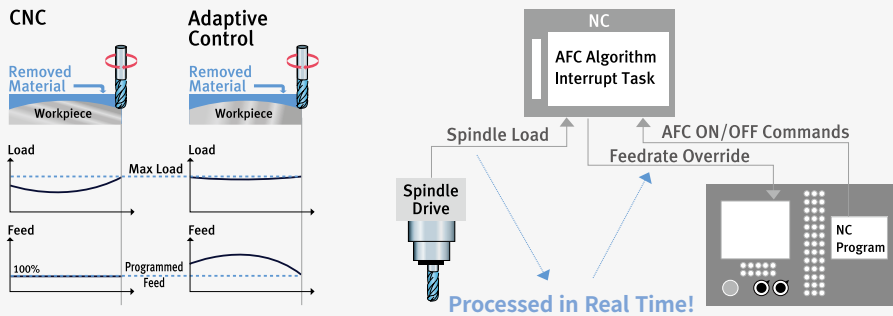

\*DAFC : DN Solutions Adaptive Feedrate Control

## Smart thermal displacement multi compensation technology

Realizes high-quality, high-precision machining with smoothing thermal displacement compensation of the spindle and structure.

### Compensation of static displacement of spindle

Compensates changes in tool position caused by expansion of the spindle shaft at high speed.

### Structure thermal displacement compensation

Compensates irregular deflection or expansion of the structure due to ambient temperature using a multiple temperature sensors.

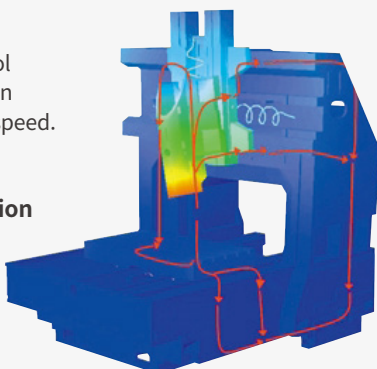

### Compensation of structure thermal displacement

Thermal error of the spindle caused by heat accumulation is compensated with 5 algorithms including a smoothing function.

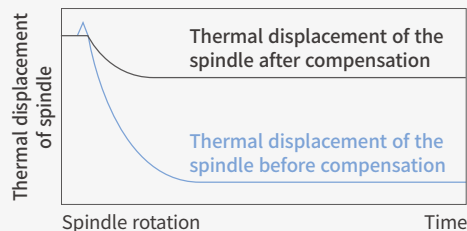
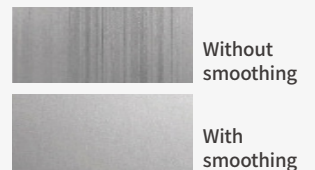

# STANDARD | OPTIONAL SPECIFICATIONS

A range of options is available to suit individual requirements.

Description	Features	MP 6500	
Electric cabinet light		○	
Electric cabinet line filter		○	
Electric cabinet air conditioner		○	
Linear scale	X Axis	○	
	Y Axis	○	
	Z Axis	○	
Coolant	Flood	●	
	Flushing	●	
	TSC	0.2 (0.15) MPa	○
		0.05 (0.05) MPa	○
		2.0(1.9) MPa	○
Spindle motor power	3.0(3.0) MPa	○	
	7.0(7.0) MPa	○	
	22/11 kW	●	
	37/22 kW	○	
	18.5/13 kW	○	
Spindle speed	5.5/3.7 kW	○	
	20000 r/min	●	
	15000 r/min	○	
	30000 r/min	○	
	40000 r/min	○	
Air gun		○	
Air blower		●	
Oil Skimmer	Belt type	○	
Auto NC power off		○	
Automatic tool changer	30 Tools	●	
	40 Tools	○	
Automatic tool measurement	TS27R : RENISHAW	●	
	Z-MT : BLUM	○	
Automatic tool measurement master tool		○	
Automatic workpiece measurement		○	
Coolant Tank		●	
Coolant Pump		●	
Gravity axis drop prevention		○	
Chip conveyor	Hinge / Scraper / Drum filter type	○	
Work & tool counter	Work / Tool	○	
Coolant gun		○	
Water soluble Coolant Chiller***		●	
Test bar	BT 40	○	
Power transformer		○	
DAFC		●	
DSTC		●	
DTMM		●	
Easy Operation Package	Tool load monitor	●	
	Alarm / M-code / G-code / ATC recovery help	●	
	Table moving for setup / Easy work coordinate setting	●	
MPG	1 MPG_PORTABLE TYPE	●	
	1 MPG_PORTABLE_W/ENABLE TYPE	○	
NC System	FANUC 31iB	●	
	HEIDENHAIN iTNC530	○	
NC system lcd size	15 inch_FANUC (Color)	●	
	15.1 inch_HEIDENHAIN (Color)	○	
Magnetic Chuck	SPIDER (SM5508C, SM5609C)	○	
	ASSFALG (508HD50, 610HD50)	○	
	Fire extinguisher (Auto)	○	
Customized special option	Coolant level switch : Sensing level - Low / High	○	
	Raising blocks	○	
	Anchoring	○	
	Auto tool length measurement	Anchoring	○
		RENISHAW / NC4	○
		BLUM / Micro-compact laser control NT	○
	Auto workpiece measurement	BLUM / Z-MT, Z-NANO HP	○
		OMRON / D5A	○
	Auto workpiece measurement	NIDDLE	○
		RENISHAW / OMP60	○
	4th axis preparation cabling for servo/ 1-pneumatic piping	Factory ready made	○
	4th axis with CNC rotary table	Φ300	○
		Depends on the table	○
	Coolant system - middle pressure TSC II		○

\* Please contact DN Solutions for detailed specification information. \*Special Quotation.

\*\* When using a semi-synthetic type or synthetic type, contact our sales representative or service center in advance.

\*\*\* Technical consultation is mandatory for the chilling of non-water soluble coolant

● Standard ○ Optional X N/A

**Fire Safety Precautions** | There is a high risk of fire when using non-water-soluble cutting fluids, processing flammable materials, neglecting the controlled and careful use of coolants and modifying the machine without the consent of the manufacturer. Always check the SAFETY GUIDELINES carefully before using the machine.

# PERIPHERAL EQUIPMENT

Help deliver excellent performance in diverse machining conditions.

## Improved spindle rigidity and life

Improved spindle rigidity in the low speed range and long spindle life for high speed operations achieved with constant pre-loaded spindle.

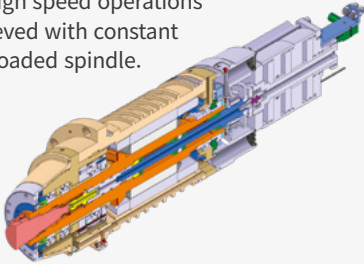

## Machine temperature controlled spindle and axis drive cooling system

Accurate spindle cooling Accurate ball screw cooling



## Auto tool measuring equipment

Tool length measurement  
Tool diameter measurement and damaged tool detection



## Chip disposal

Efficient and effective chip management systems and options improve productivity and performance and help ensure a better working environment.

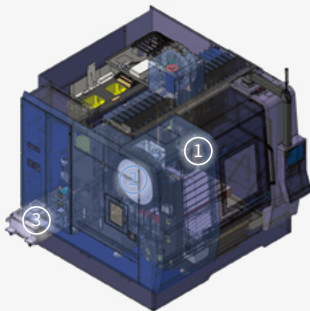

### 1. Coolant system

Side coolant chip air blower.  
Coolant residue stopping device



### 2. Barrier between the magazine and cutting area

The tool magazine is protected from the cutting area with an automatic door.

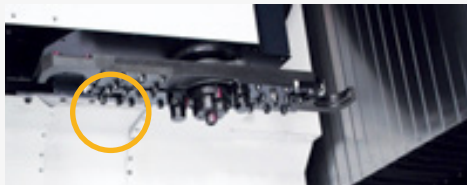

### 3. Chip conveyor OPTION

MP 6500 - Side exhaust

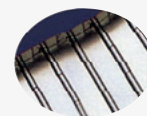

Hinge type

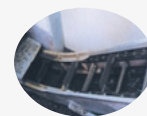

Scraper type

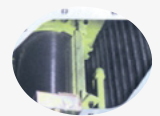

Drum filter type

## Coolant chiller

The chiller lowers coolant temperature, helping to cool both the workpiece and tool during machining operations.

When using insoluble cutting oils, a coolant chiller is recommended to cool the oil and maintain machining precision.

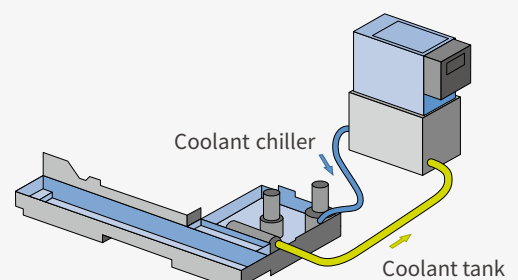

# CONVENIENCE

Operator convenience and work efficiency have been improved through the adoption of various convenient control functions and the machine's ergonomic design.

## Operating console



1. 15" Color TFT LCD Monitor



2. Mono lever



3. Membrane keyboard



4. Portable MPG LCD Portable MPG Handle **OPTION**



5. Hot Key



6. Temperature display device **OPTION**

Operators can check the processing area, coolant, bed and temperature on the display.

## Convenient absolute feed

The current position of the machine is stored and maintained using battery power. Zero point return is not necessary after a power cycle interruption.

## Excellent accessibility

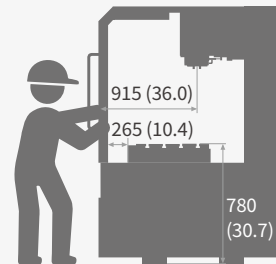

Unit : mm (inch)

## System condition indicator

**Warning lamp**  
Reports abnormal operating condition of the machine

**Work completion indicator**  
Indicates that the work is finished

**In-progress lamp**  
Indicates that the work is being carried out

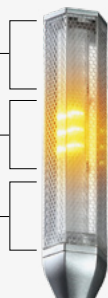

## LED indoor work light

LED lamp provides higher brightness and longer life with reduced energy consumption.



# FANUC 31iB PLUS

Fanuc 31i Plus maximizes customer productivity and convenience.

## 15" Touch screen + New OP

DN Solutions Fanuc 31iB/B5 Plus' operation panel enhances operating convenience by incorporating common-design buttons and layout. It features a Qwerty keyboard for fast and easy data input and operation.

## FANUC 31i PLUS

- 15-inch color display
- Intuitive and user-friendly design
- USB and PCMCIA card QWERTY keyboard**
  - EZ-Guide i standard
  - Ergonomic operator panel
  - Enhance AICC BLOCK
  - Touch pen provided as standard
  - 4MB Memory
  - Hot keys



## iHMI touchscreen

iHMI provides an intuitive interface that uses a touchscreen for quick and easy operation.

## Range of applications

Providing various applications related to planning, machining, improvement and utility, for customer convenience.



## NUMERIC CONTROL SPECIFICATIONS



Item		Specifications	F31iB Plus MP 6500
Controlled axis	Controlled axes		5 (X,Y,Z)
	Simultaneously controlled axes		5 axes
	Additional controlled Axis	Add 1 Axis (5th Axis)	○
Data input/output	Fast data server		○
	Memory card input/output		●
	USB memory input/output		●
	Large capacity memory(2GB)*2	Note *2) Available Option only with 15" Touch LCD (iHMI Only)	○
Interface function	Embedded Ethernet		●
	Fast Ethernet	1GB *2)	●
	Enhanced Embedded Ethernet function		●
Operation	DNC operation	Included in RS232C interface.	●
	DNC operation with memory card		●
Program input	Workpiece coordinate system	G52 - G59	●
	Addition of workpiece coordinate system	G54.1 P1 X 48 (48 pairs)	●
	Tool number command		T4 digits
	Tilted working plane indexing command	G68.2 TWP	○
Feed function	AI contour control I	G5.1 Q_, 40 Blocks	X
	AI contour control II	G5.1 Q_, 200 Blocks	X
	AI contour control II	G5.1 Q_, 600 Blocks	X
	AI contour control II	G5.1 Q_, 1000 Blocks	●
	High smooth TCP		X
Operation guidance function	EZ Guidei (Conversational Programming Solution)		●
	iHMI with Machining Cycle	Note *1) Only with 15" Touch LCD standard	X
	EZ Operation package		●
Setting and display	CNC screen dual display function		●
Network	FANUC MTConnect		●
	FANUC OPC UA		⊗
Others	Display unit	10.4" color LCD	X
		15" color LCD	X
		15" color LCD with Touch Panel	●
	Part program storage size & Number of registerable programs	640M(256KB)_500 programs	X
		1280M(512KB)_1000 programs	○
		2560M(1MB)_1000 programs	○
		5120M(2MB)_1000 programs	○
		10240M(4MB)_1000 programs	●
		20480M(8MB)_1000 programs	○
		2560M(1MB)_2000 programs	○
		5120M(2MB)_4000 programs	○
		10240M(4MB)_4000 programs	○
		20480M(8MB)_4000 programs	○

# EZ WORK

The software developed by DN Solutions features numerous functions designed for convenience and ease of operation.

## EZ work

The EZ work delivers speed and efficiency. This menu-driven innovation not only helps customers reduce setup times, but also simplifies common tasks and procedures, reducing the potential for errors. EZ work reduces operating time, protects machinery, enhances quality and speeds up maintenance interventions.

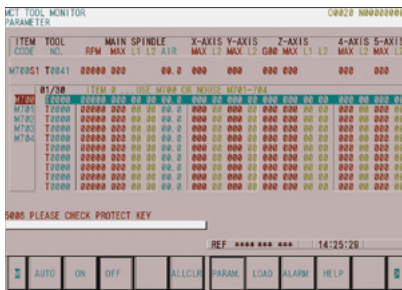

### Tool Load Monitor

Function to automatically monitor tool load (Dierent loads can be set for one tool according to M700 ~ M704)



### M/G-Code List

Functional description of M code and G code

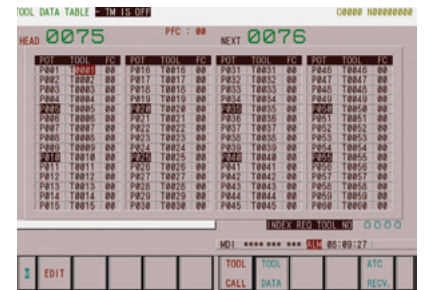

### Tool Management

Function to manage tool information [Tool information / Tool No. / Tool condition (normal, large diameter, worn / damaged, used for the rst time, manual) / Tool name]



### Operation Rate

Machine operation history management function by date based on load



### Adaptive Feed Control

Function to control feedrate so that the cutting can be carried out at a constant load (To adapt to the spindle load set up with constant load feedrate control function)

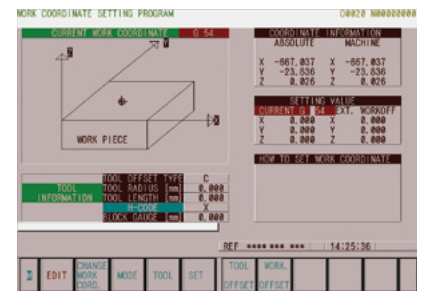

### Work Offset Setting

Function to congure various work oset settings



### Spindle Warm Up

A function that assists spindle warm-up for spindle life when the spindle has not been used for a certain period of time



### ATC Recovery

Function to view detailed info with recommended actions and to perform step-by-step operation manually (when an alarm is triggered during an ATC operation)

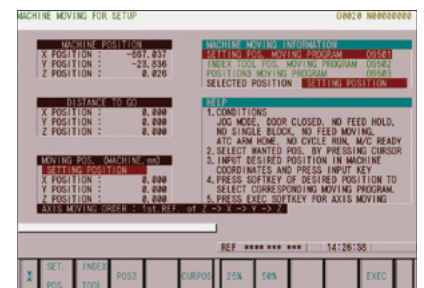

### Machine Move

A function to store frequently moved locations and use them as soft keys

# CONVENIENT OPERATION

## SIENUMERIK ONE

### Even Faster & Easier processing + 398mm screen

All programming, set-up, actual machining and verification process are getting easier and faster. Especially, intuitive conversational programming guidance with 3D UI(user interface) on 18.5" large touch screen is helpful for unskilled engineers.

- 18.5 inch touch screen
- 50% improvement in processing speed (compared to S840D)
- Graphic programming
- PLC-based flexible automation/peripheral device expandability



### Conversational convenient function

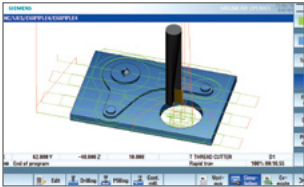

Simulation and machining contour monitoring

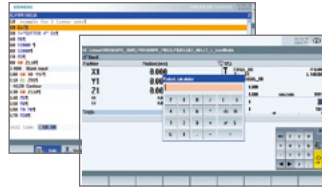

Smart function

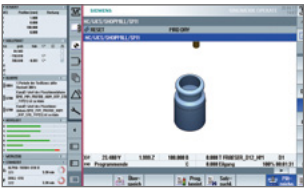

Side screen widget

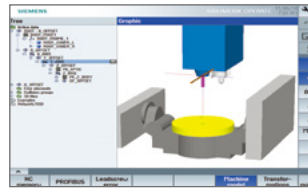

3D collision avoidance and collision avoidance ECO

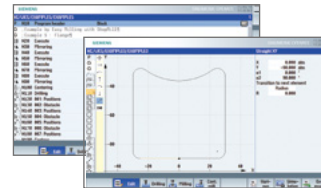

Shop mill part programming

## NUMERIC CONTROL SPECIFICATIONS

## SIEMENS

Item	Specifications	S-ONE
Controlled axis	Controlled axes	5 (X,Y,Z)
	Simultaneously controlled axes	5 axes
Data input/output	Memory card input/output	●
	USB memory input/output	●
Interface function	Ethernet	●
Operation	On network drive	●
	On USB storage medium, e.g. memory stick	● (without EES option, Extcall)
Program input	Workpiece coordinate system	●
	Addition of workpiece coordinate system	●
Interpolation & Feed function	Top surface	○
	Look ahead number of block	1000
Programming & Editing function	3D simulation, finished part	●
	Simultaneous recording	●
	DXF Reader for PC integrated in SINUMERIK Operate	○
Operation Guidance Function	ShopMill	●
	EZ Work	●
Setting and display	Operation via a VNC viewer	●
Network	MTConnect	●
	OPCUA	○
Others	18.5" color display with touch screen	●
	21.5" color display with touch screen	○
	CNC user memory	10 MB
	Max. CNC user memory	28 MB
	Collision avoidance (machine, working area)	○
Collision avoidance ECO (machine, working area)	○	

# CONVENIENT OPERATION

## HEIDENHAIN TNC7

### Visualized, intuitive task support, customized UI

The TNC7 makes machining even easier, for everything from programming to program validation and from machine setup to actual machining. You intuitively operate highly complex applications directly on the touchscreen with various integrated solutions for standard tasks.

### TNC7 NEW

- 24 inch touch screen
- 189GB Program memory
- Look-ahead 5000 blocks
- Touch Probe Cycles Graphical Programming



< TNC7 >

### Conversational convenient function



Data are controlled in the folder structure; convenient communication via USB devices



KinematicOpt & KinematicComp OPTION  
(Touch probe cycle for automatic measurement)

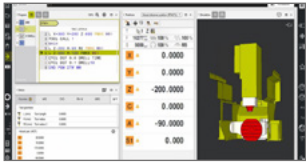

Collision protection system OPTION

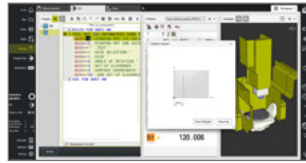

Various built-in pattern cycles for a wider scope of application (Software standard)



Graphic simulation



Enhanced collision protection function DCMv2 OPTION



Improved maintenance environment

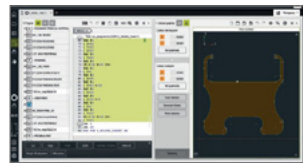

Highly practical programming and setup based on touch operation

## NUMERIC CONTROL SPECIFICATIONS

## SIEMENS

Item		Specifications	TNC7
<b>Controlled axis</b>	Controlled axis		5 (X,Y,Z)
	Simultaneously controlled axis		5 axes
<b>Interface function</b>	Embedded ethernet		●
	USB interface (USB 2.0)		●
<b>Feed function</b>	Look-ahead	5000 blocks	●
<b>Axis compensation</b>	KinematicsOpt	Automatic measurement and optimization of machine kinematics	●
<b>Collision monitoring</b>	Dynamic collision monitoring (DCM)		○
<b>Network</b>	MT Connect		★
<b>Others</b>	Display unit	touch panel	24"
	Program memory for NC programs		189GB

# POWER | TORQUE

## 20000 r/min

Max. spindle speed  
**22 kW** (29.5 Hp)

Spindle motor power  
**60 N·m** (44.3 ft-lb)

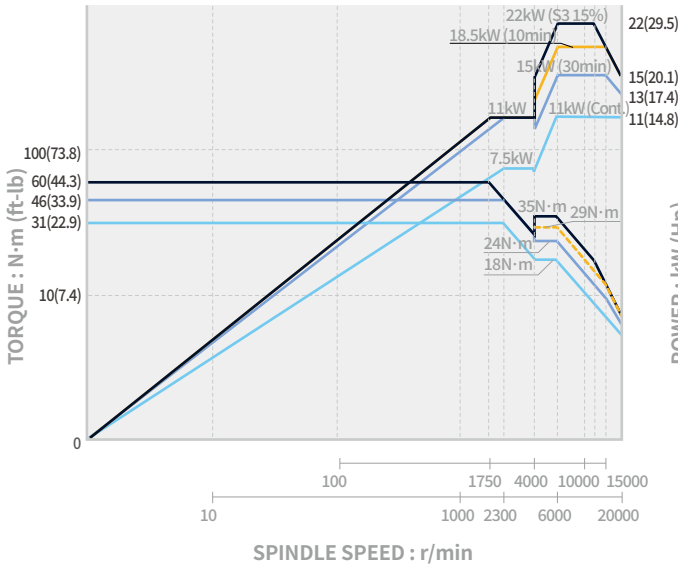

## 15000 r/min OPTION

Max. spindle speed  
**37 kW** (49.6 Hp)

Spindle motor power  
**303 N·m** (223.6 ft-lb)

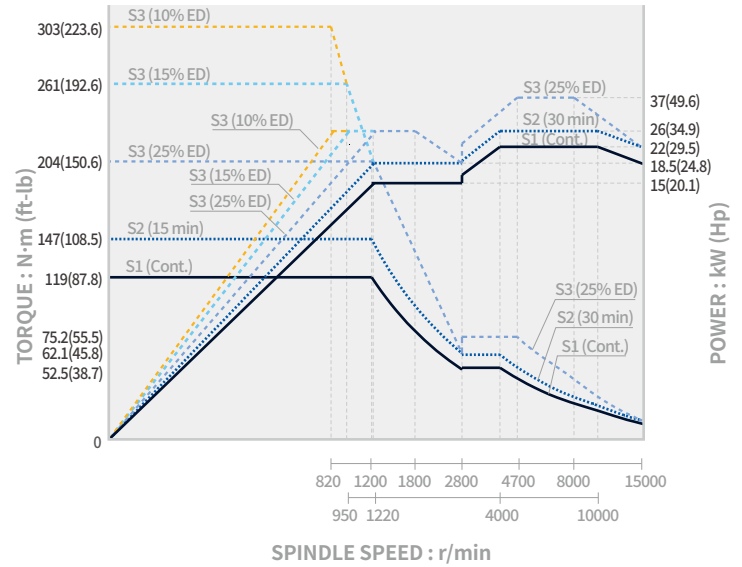

## 30000 r/min OPTION

Max. spindle speed  
**18.5 kW** (24.8 Hp)

Spindle motor power  
**5.9 N·m** (4.4 ft-lb)

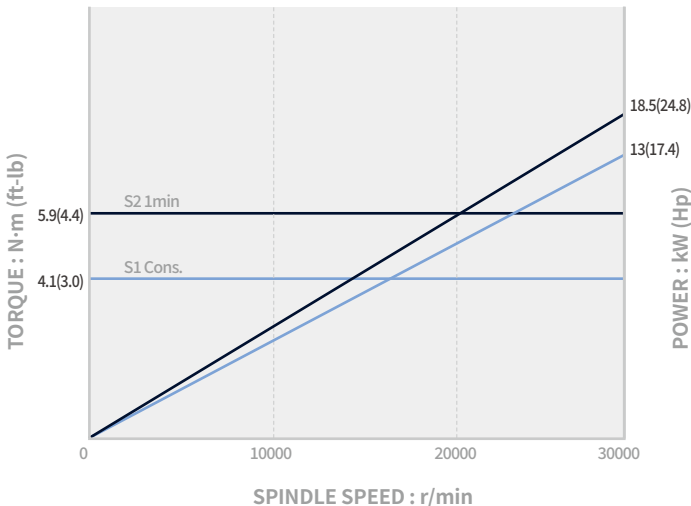

## 40000 r/min OPTION

Max. spindle speed  
**5.5 kW** (7.4 Hp)

Spindle motor power  
**3.5 N·m** (2.6 ft-lb)

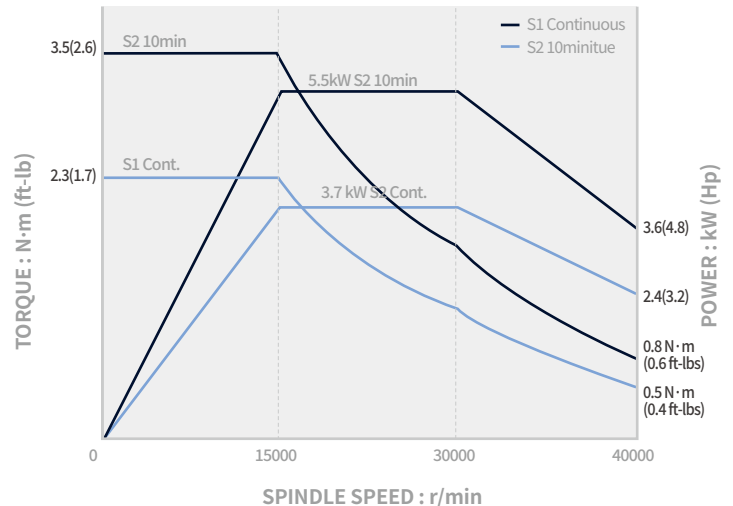

# DIMENSIONS

Units : mm (inch)

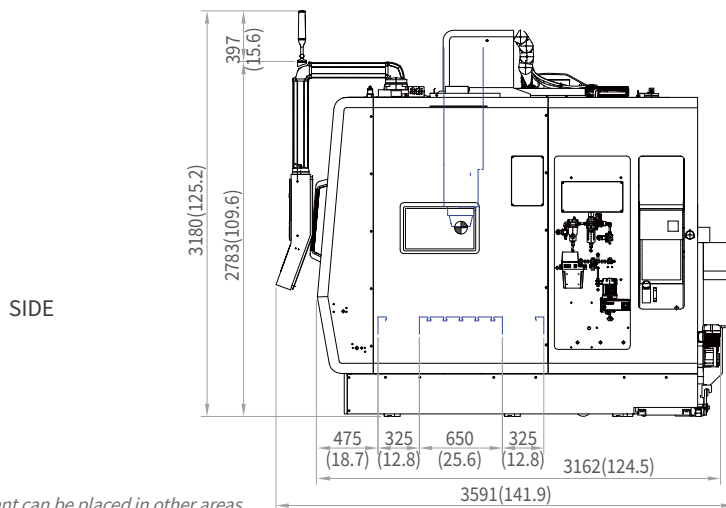
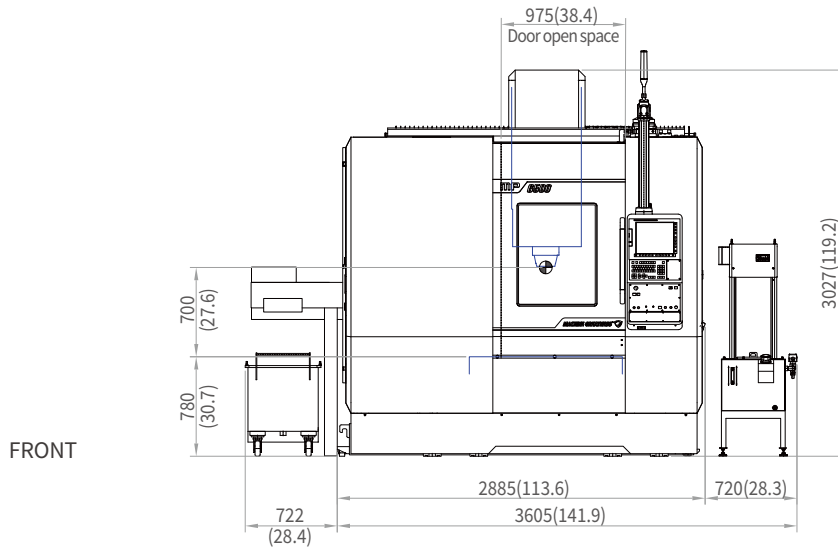
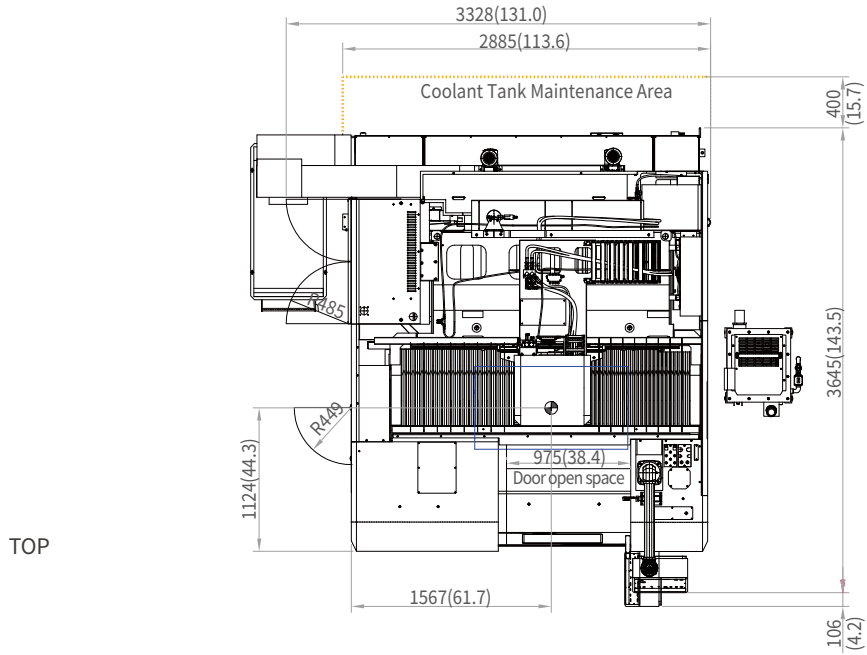

\* Some peripheral equipment can be placed in other areas.



# MACHINE SPECIFICATIONS

Item		Unit	MP 6500
Travels	X, Y, Z axis	mm (inch)	1100 / 650 / 550 (43.3 / 25.6 / 21.7)
	Distance from spindle nose to table top	mm (inch)	150 ~ 700 (5.9 ~ 27.6)
Feedrates	Rapid traverse (X / Y / Z axis)	m/min (ipm)	30 / 30 / 30 (1181.1 / 1181.1 / 1181.1)
	Cutting feedrate	mm/min (ipm)	15 (0.6)
Table	Table size	mm (inch)	1200 x 650 (47.2 x 25.6)
	Table loading capacity	Kg (lb)	800 (1763.7)
Spindle	Max. spindle speed	r/min	20000 {15000, 30000, 40000}
	Spindle motor (10min/cont.)	kW (Hp)	22 / 11 {37/22, 18.5/13, 5.5/3.7}* (29.5 / 14.8 {49.6/29.5, 24.8/17.4, 7.4/5.0})
	Taper spindle	Taper	ISO #40 {ISO #40, HSK-F63, HSK-E40}*
	Max. spindle torque (10min)	N.m (ft-lbs)	60 {303, 5.9, 3.5}* (44.3 {223.6, 4.4, 2.6})
Automatic Tool Changer	Number of tools	ea	30 {40}
	Max. tool diameter	mm (inch)	80 (3.1)
	Max. tool diameter without adjacent tools	mm (inch)	125 (4.9)
	Max. tool length	mm (inch)	300 (11.8)
	Max. tool weight	Kg (lb)	8 (17.6)
	Max. tool moment	N·m (ft-lbs)	7.84 (5.8)
	Tool change time (tool-to-tool)	s	1.6
Power Source	Electric power supply	kVA	48.55 {54.4, 46.93, 35.05}*
Tank Capacity	Coolant tank capacity	L (gal)	300 (79.3)
	Lubrication tank capacity	L (gal)	4.3 (1.1)
Machine Dimensions	Length x Width	mm (inch)	2820 x 3315 (111.0 x 130.5)
	Height	mm (inch)	3036 (119.5)
	Weight	Kg (lb)	10000 (22045.9)
NC system		-	F31iB Plus



**Head Office**

19F, 10, Tongil-ro, Jung-gu, Seoul,  
Republic of Korea, 04527

Tel: +82-2-6972-0370  
Fax: +82-2-6972-0400

**DN Solutions America**

360 E State PKWY,  
Schaumburg, IL. 60173,  
United states

Tel: +1-315-265-7500

**DN Solutions Europe**

Emdener Strasse 24, D-41540  
Dormagen, Germany

Tel: +49-2133-5067-100  
Fax: +49-2133-5067-111

**DN Solutions India**

No.82, Jakkuar Village  
Yelahanka Hobil,  
Bangalore-560064

Tel: +91-80-2205-6900  
E-mail: [india@dncompany.com](mailto:india@dncompany.com)

**DN Solutions China**

Room 101,201,301,  
Building 39 Xinzhuan Highway  
No.258 Songjiang District  
China Shanghai (201612)

Tel: +86 21-5445-1155  
Fax: +86 21-6405-1472

**DN Solutions Vietnam**

M.O.R.E building 2F, 40A-40B Ut  
Tich Street, 04 Ward 04,  
District Tan Binh District,  
Ho Chi Minh City, Vietnam

Tel: +84 28-7304-0163

**DN Solutions Mexico**

Avenida Parque Bicentenario  
#100 Nave M65L3-6,  
Fraccionamiento San Isidro  
Business Park,  
Santa Rosa Jauregui,  
Querétaro, México

E-mail: [efrain.figueroa@dncompany.com](mailto:efrain.figueroa@dncompany.com)

**Sales inquiry**

[sales@dncompany.com](mailto:sales@dncompany.com)