

HIGH-PRECISION, HIGH-SPEED VERTICAL MACHINING CENTER

# **NX 5500II**

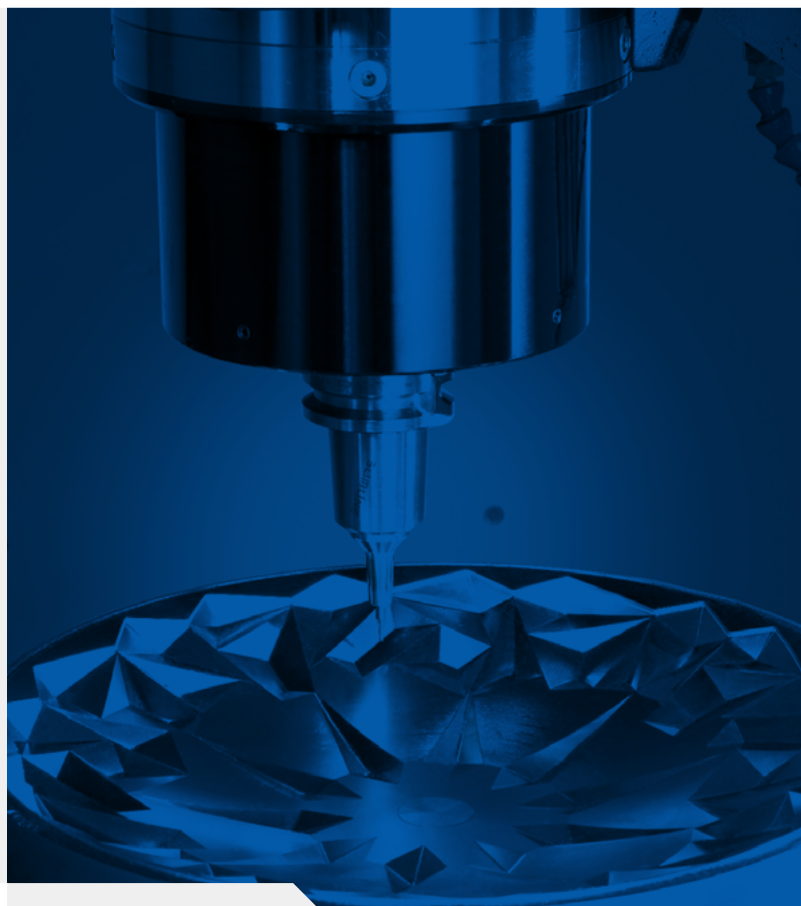

# NX 5500II

The NX 5500 II vertical machining centers are designed with a thermal-symmetric bridge type structure to optimise precision and workpiece quality. High accuracy is also enhanced by the constant pre-load high speed spindle. Operator convenience is improved by optimum accessibility and operator functions.

## CONTENTS

### Product Overview

### Basic Information

- 04 Basic Structure
- 05 Axis System
- 05 Tool Change System
- 06 Spindle | Table
- 07 Optimized Tool Processing Solution

### Detailed Information

- 08 Standard | Optional Specifications
- 09 Peripheral Equipment
- 11 Fancu 31i-B Plus
- 12 EZ Work
- 13 Convenient Operation
- 14 Power | Torque
- 15 External Dimensions
- 16 Table Dimensions
- 17 Machine Specifications

### Customer Support Service

- 18 Why DN Solutions
- 19 Customer Support and Services
- 19 Global Network



### IMPROVED SPINDLE RIGIDITY AND LIFE



- Improved spindle rigidity in low speed range and achieved long spindle life with constant pre-load spindle in high speed range.

### STABLE BRIDGE TYPE STRUCTURE



- Thermal analysis of the symmetrical structure and minimal overhang of the bridge type machine structure provide optimal solution for high-speed / high-precision processing.

### OPTIMIZED MOLD PROCESSING SOLUTION



- Thermal error compensation system, high speed spindle, high accuracy contour control, tool measurement system are provided as standard to improve mold processing performance.

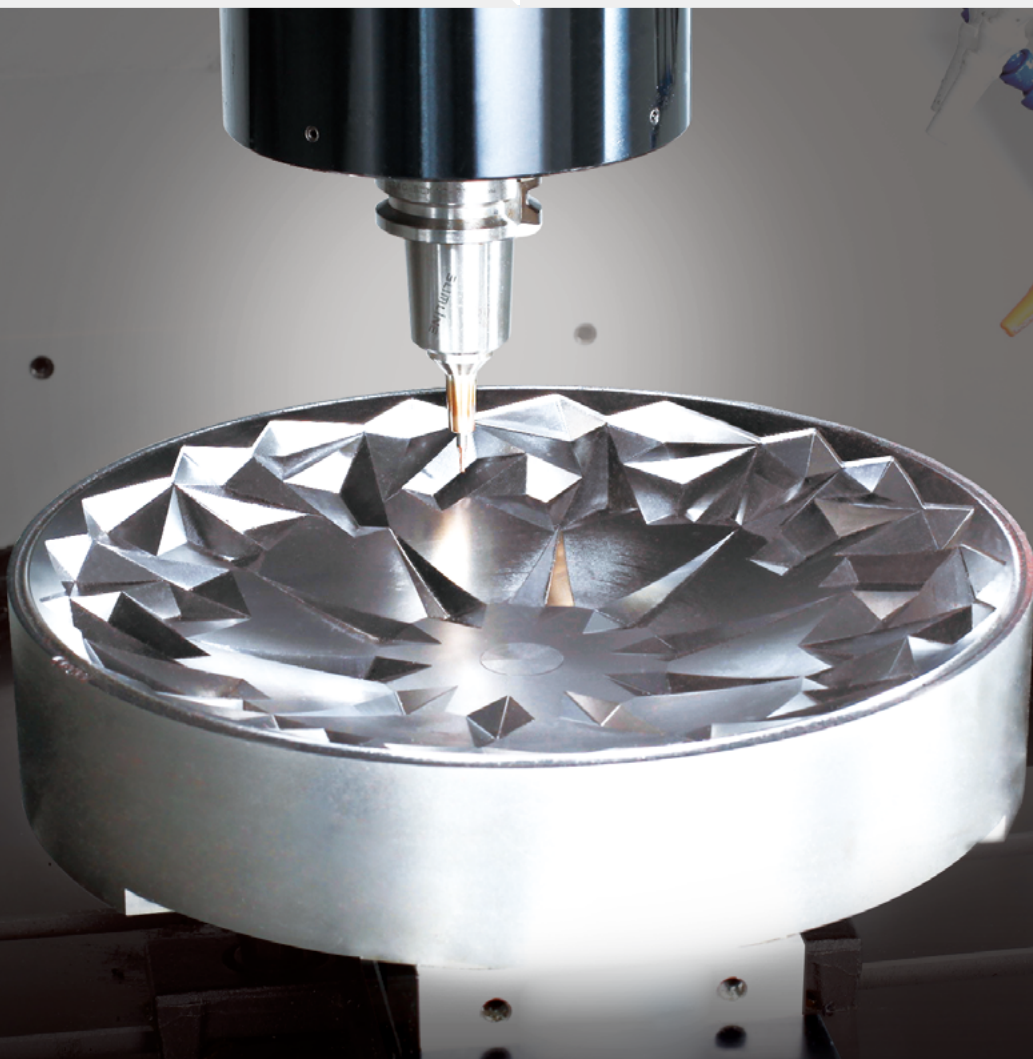

# BASIC STRUCTURE

NX II series have the Bridge type structure for high-performance, high-accuracy machining.

## Bridge type structure

Thermal analysis of the symmetrical structure proves that this is the optimal solution for high precision machining of mild products.

### Traver distance

X axis  
**900** mm (35.4 inch)

Y axis  
**550** mm (21.7 inch)

Z axis  
**500** mm (19.7 inch)

### Rapid traverse rate (X / Y / Z axis)

**30 / 30 / 30** m/min  
(1181.1 / 1181.1 / 1181.1 ipm)



## Gravity center drive structure

By minimizing the distance between gravity center and the feed drive center, the inertia movement is reduced allowing for faster feed rates and a more precise part.

## Oil separator (NX 5500II)

Coolant and sliding oil are separated in the bed structure.

### Gravity Center Drive Structure

Unit : mm (inch)

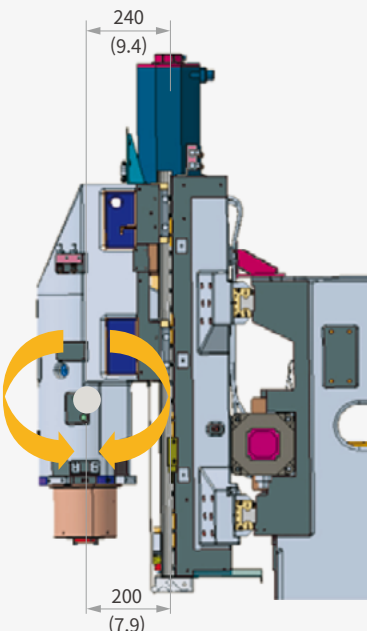

### Oil Separator

Coolant →  
sliding oil →

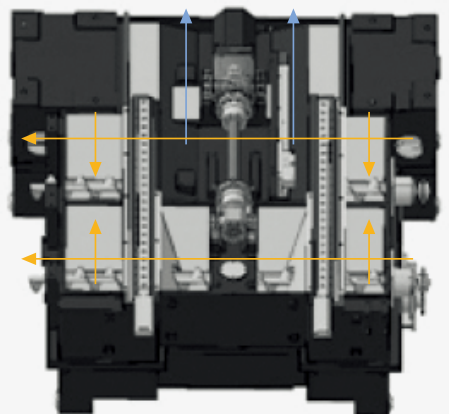

# AXIS SYSTEM

The linear axes are equipped with roller linear Guideways for increased rigidity and a cooling system as standard features to minimize thermal error.

## High-precision travel system

Roller-type linear Guideways, high-rigidity coupling, and nut cooling system achieve high rigidity and outstanding linear axis accuracy of linear feed drive system.

### Roller linear guideway

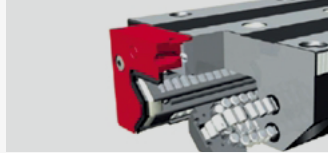

### Rigid coupling

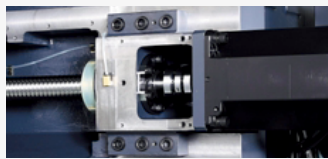

### Ball screw nut cooling

Reduced thermal error of feed shafts  
Stable rigidity of the feed system

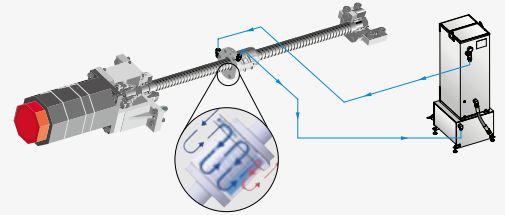

## High power servo motor

The responsiveness of each axis feed system is improved by reducing the load / motor inertia ratio by 50%.

### NX II series

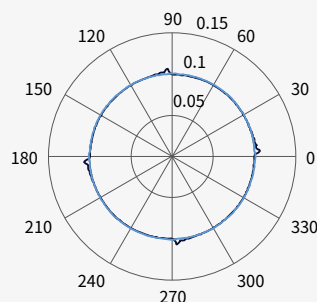

### General processing system

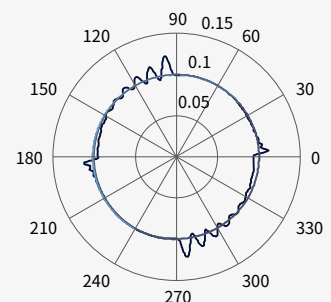

# TOOL CHANGE SYSTEM

Rapid tool change reduce idling time and improves productivity.

## Automatic tool changer

Enhanced productivity achieved with the high speed tool changer.

Tool storage capacity

**30** ea

Tool to tool time

**1.6** sec

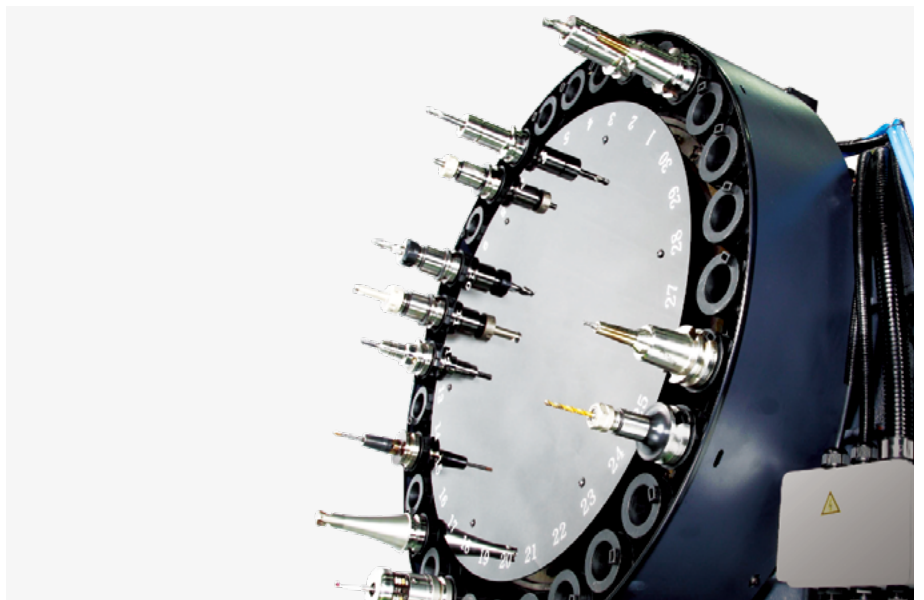

# SPINDLE | TABLE

High-precision spindle and excellent dynamic balancing ensures stable surface accuracy by minimizing vibration in high speed cutting.

## High-rigidity, high-precision spindle

Adopting a new constant preloading structure, improved spindle rigidity in low speed range and achieved long spindle life.

Max. spindle speed

**20000** r/min

**30000** r/min OPTION

**40000** r/min OPTION

Spindle motor power

**22 / 11** kW (30 / 15 Hp)

## Spindle cooling system

Cooling system removes heat generated at the bearings and motor to minimize thermal error. The air-oil structure supplies high pressure air and lubricant to the spindle bearings to remove the heat generated at the bearings and extend service life of the machine tool.

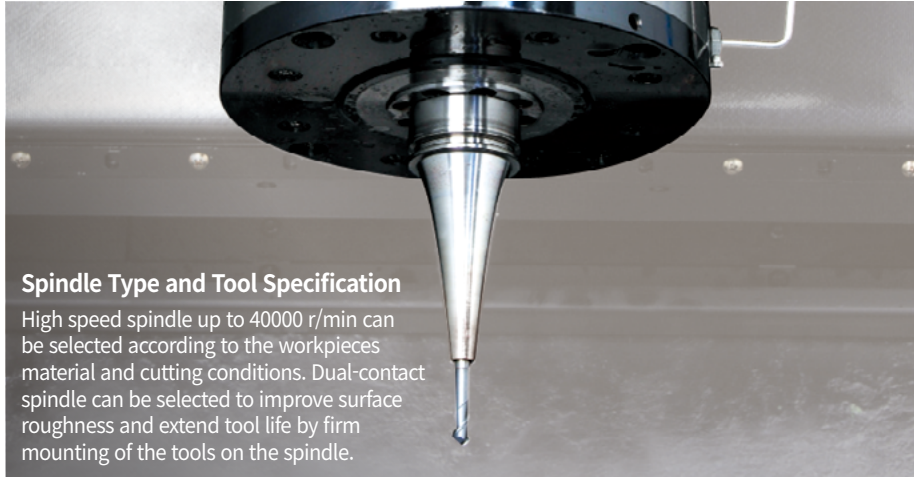

### Spindle Type and Tool Specification

High speed spindle up to 40000 r/min can be selected according to the workpieces material and cutting conditions. Dual-contact spindle can be selected to improve surface roughness and extend tool life by firm mounting of the tools on the spindle.

Item	20000 r/min		30000 r/min	40000 r/min
	std.	opt.	<small>OPTION</small>	<small>OPTION</small>
Spindle motor power kW (Hp)	22 / 11 (30 / 15)	22 / 11 (30 / 15)	18.5 / 13 (25 / 17)	5.5 / 3.7 (7 / 5)
Taper spindle	BBT 40	HSK-A63	HSK-F63	HSK-E40

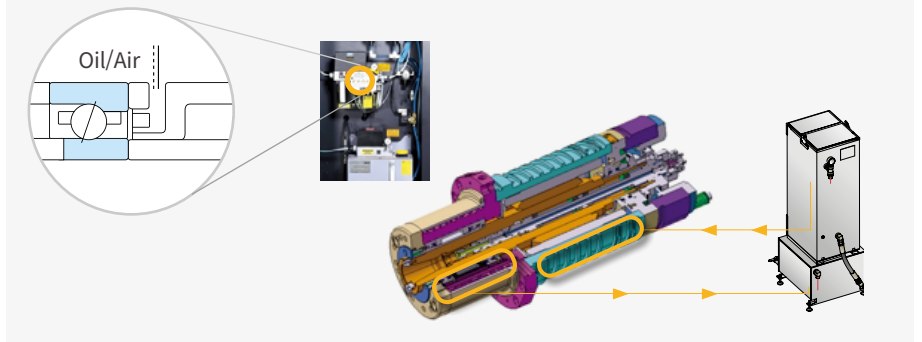

# TABLE

Wide cutting area for cutting various workpieces.

## Wide cutting area

The size and load capacity of the table allow the setting up and cutting of larger workpieces of various shapes.



Item	Unit	NX 5500 II
Table size	mm (inch)	1000 x 550 (39.4 x 21.7)
Table loading capacity	kg (lb)	700 (1543)

# OPTIMIZED TOOL PROCESSING SOLUTION

Superior surface finishes and superior machining precision are achieved by using standard DN Solutions processing solutions, such as high speed / high precision contour control and thermal displacement compensation functions.

## Tool load monitoring system (DTMM\*)

The technology that protects the tool and machine when machining abnormal loads.

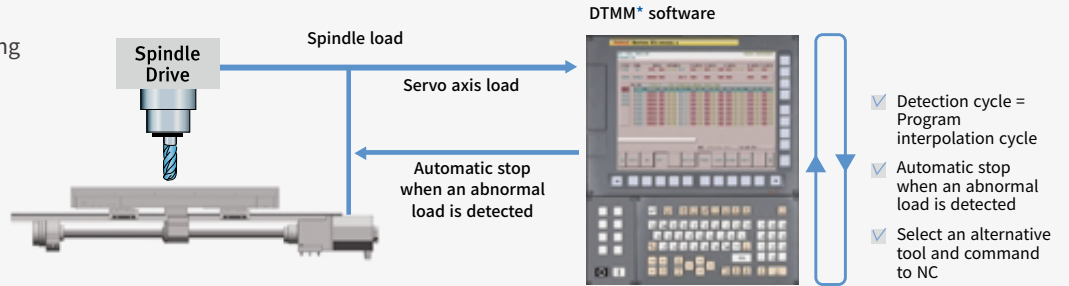

\*DTMM : DN Solutions Tool load Monitoring for Machining Centers

## The optimal feed control (DAFC\*)

Optimal feed control is ensured by spindle load detection that occurs in real time.

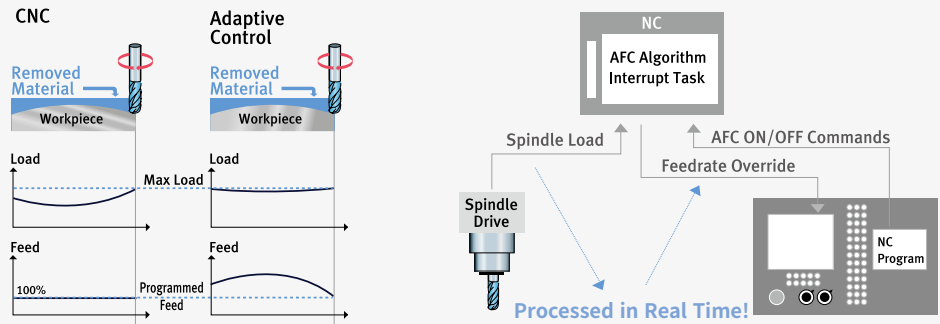

\*DAFC : DN Solutions Adaptive Feedrate Control

## Smart, multi-compensation thermal displacement technology

Realization of high-quality, high-precision machining achieved by thermal compensation of the spindle and machine structure.

### Compensation of static spindle displacement

Compensates for changes in tool position caused by expansion of the spindle shaft during high speed operations.

### Structural thermal displacement compensation

Compensates for any irregular deflection or expansion of the structure due to ambient temperature fluctuation by using multiple temperature sensors.

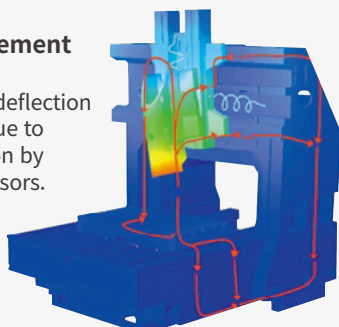

### Thermal displacement compensation structure

Thermal displacement of the spindle, caused by heat accumulation, is compensated for using 5 algorithms including a smoothing function.

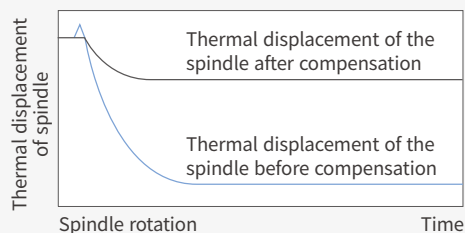

Without smoothing

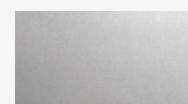

With smoothing

\*DSTC : DN Solutions Smart Thermal Control

# STANDARD | OPTIONAL SPECIFICATIONS

A range of options is available to suit individual requirements.

Description	Features	NX 5500 II	
Air blower		●	
Air gun		○	
Auto NC power off		○	
Auto workpiece measurement		○	
Automatic tool changer	24 Tools	X	
	30 Tools	●	
Automatic tool measurement	TS27R : RENISHAW	●	
	Z-MT : BLUM	○	
Automatic tool measurement master tool		○	
Chip conveyor	Hinge / Scraper / Drum filter type	○	
Water soluble Coolant Chiller**		○	
Coolant gun		○	
Coolant Pump		●	
Coolant Tank		●	
DAFC		●	
DSTC		●	
DTMM		○	
Easy Operation Package	Tool load monitor	●	
	Alram / M-code / G-code / ATC recovery help	●	
	Table moving for setup / Easy work coordinate setting	●	
Electric cabinet air conditioner		○	
Electric cabinet light		○	
Electric cabinet line filter		○	
Gravity axis drop prevention		○	
Linear scale	X Axis	○	
	Y Axis	○	
	Z Axis	○	
MPG	1 MPG_PORTABLE TYPE	●	
	1 MPG_PORTABLE_W/ENABLE TYPE	○	
NC System	FANUC 31iB	●	
	HEIDENHAIN iTNC530	○	
NC system lcd size	10.4 inch_FANUC (Color)	X	
	15.1 inch_HEIDENHAIN (Color)	●	
Oil Skimmer	Belt type	○	
Power transformer		○	
Spindle motor power	22 / 11 kW (30 / 15 Hp)	●	
	18.5 / 13 kW (25 / 17 Hp)	○	
	5.5 / 3.7 kW (7 / 5 Hp)	○	
Spindle speed	20000 r/min	●	
	30000 r/min	○	
	40000 r/min	○	
Test bar	BT 40	○	
Through spindle coolant	NONE	●	
	1.5 kW (2 Hp)_2.0 MPA (2 Hp)	○	
	5.5 kW (7.4 Hp)_7.0 MPA_DUAL BAG FILTER	○	
Work & tool counter	WORK / TOOL	○	
	ANCHORING	J-BOLT	○
Customized special option	COOLANT CHILLER	○	
	AUTO TOOL LENGTH MEASUREMENT	MAKER/SPEC._RENISHA/NC4	○
		MAKER/SPEC._BLUM/MICROCOMPACT LASER CONTROL NT	○
	AUTO TOOL BREAKAGE DETECTION	MAKER/SPEC._BLUM/Z-MT, Z-NANO HP	○
		MAKER/SPEC._OMRON / D5A	○
	4TH AXIS PREPARATION CABLING FOR SERVO/1-PNEUMATIC PIPING	MAKER/SPEC._NIDDLE	○
		FACTORY READY MADE	○
	4TH AXIS WITH CNC R.TABLE	AVAILABLE SIZE_Φ500	○
SERVO MOTOR_EPENDS ON THE TABLE		○	

\* Please contact DN Solutions for detailed specification information.

\* When using a semi-synthetic type or synthetic type, contact our sales representative or service center in advance.

\*\* Technical consultation is mandatory for the chilling of non-water soluble coolant

● Standard ○ Optional X Not applicable

# PERIPHERAL EQUIPMENT

## Optional equipments

Deliver excellent performance on diverse machining conditions.



**1. Constant pre-load**

Constant pressure spindle for high rigidity in low speed range and long life in high speed range.

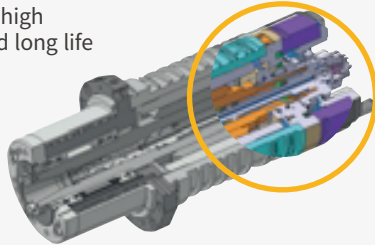

**2. Standard chip pan and chip disposal**

Chips are discharged to left side via screw conveyor.



**3. Coolant chiller (strongly recommended)**

**OPTION**

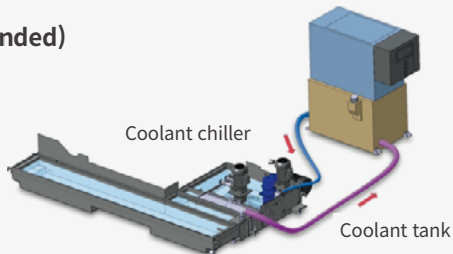

**4. Machine temperature controlled spindle and axis drive cooling system**

Accurate spindle cooling  
Accurate ball screw cooling



**5. Auto tool measuring equipment**

Tool length measurement  
Tool diameter measurement  
Damaged tool detection



**6. Graphite cutting solution **OPTION****

Fine graphite powder sealing.  
Wet/dry chip disposal

# PERIPHERAL EQUIPMENT

## Chip disposal

Through rapid discharge of chips, it maintains a high degree of efficient processing, and supports the operator to work in improved environment by providing a variety of chip treatment devices.

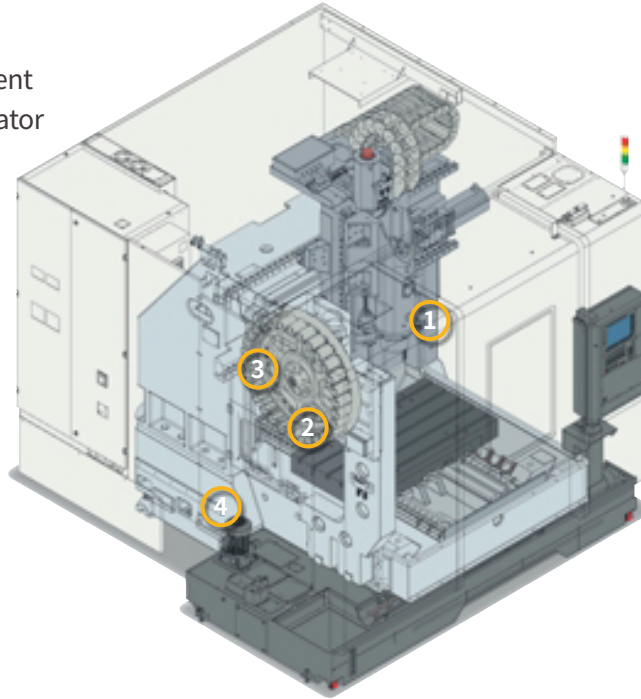

### 1. Coolant system

Side coolant chip air blower. Coolant residue stopping device

Spindle face coolant

**OPTION**

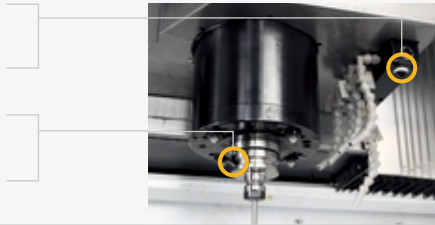

### 2. Screw conveyor

Two-rows screw type.

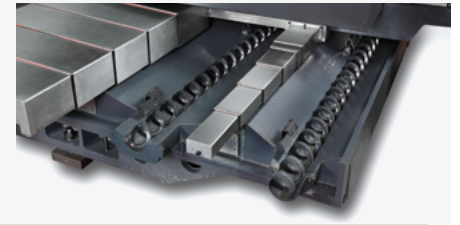

### 3. Barrier between the magazine and cutting area

The tool storage of the magazine is protected from the cutting area with an automatic door.



### 4. Chip conveyor **OPTION**

NX 5500 II - Rear discharge

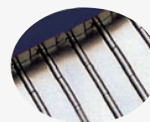

Hinge type



Scraper type

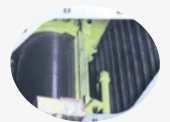

Drum filter type

### Coolant chiller (highly recommended) **OPTION**

The coolant chiller lowers coolant temperature, helping to cool both the workpiece and tool during the machining operation. When using insoluble cutting oils, a coolant chiller is recommended to cool heated oil and preserve machining precision.

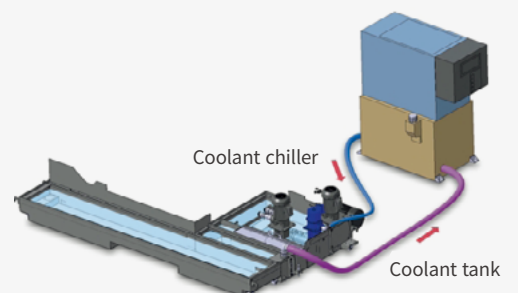

# FANUC 31iB5 PLUS

Fanuc 31i Plus maximizes customer productivity and convenience.

## 15" Touch screen + New OP

DN Solutions Fanuc 31iB/B5 Plus' operation panel enhances operating convenience by incorporating common-design buttons and layout. It features a Qwerty keyboard for fast and easy data input and operation.

## FANUC 31iB5 PLUS

- 15-inch color display
- Intuitive and user-friendly design

## USB and PCMCIA card QWERTY keyboard

- EZ-Guide i standard
- Ergonomic operator panel
- 4MB Memory
- Hot keys
- Enhance AICC BLOCK
- Touch pen provided as standard



## iHMI touchscreen

iHMI provides an intuitive interface that uses a touchscreen for quick and easy operation.

## Range of applications

Providing various applications related to planning, machining, improvement and utility, for customer convenience.



## NUMERIC CONTROL SPECIFICATIONS

FANUC

Item	Specifications	F31iB Plus	
		NX 5500 II	
Controlled axis	Controlled axes	5 (X,Y,Z)	
	Simultaneously controlled axes	5 axes	
Data input/output	Additional controlled Axis	●	
	Fast data server	○	
	Memory card input/output	●	
	USB memory input/output	●	
Interface function	Large capacity memory(2GB) *2)	○	
	Embedded Ethernet	●	
	Fast Ethernet	1GB *2)	
Operation	Enhanced Embedded Ethernet function	●	
	DNC operation	Included in RS232C interface.	
	DNC operation with memory card	●	
Program input	Workpiece coordinate system	G52 - G59	
	Addition of workpiece coordinate system	G54.1 P1 X 48 (48 pairs)	
	Tool number command	●	
Feed function	Tilted working plane indexing command	T4 digits	
	AI contour control I	○	
	AI contour control II	G5.1 Q_, 40 Blocks	
	AI contour control II	G5.1 Q_, 200 Blocks	
	AI contour control II	G5.1 Q_, 600 Blocks	
Operation guidance function	AI contour control II	G5.1 Q_, 1000 Blocks *1)	
	High smooth TCP	●	
	EZ Guidei (Conversational Programming Solution)	X	
Setting and display	iHMI with Machining Cycle	○	
	EZ Operation package	●	
Network	CNC screen dual display function	●	
	FANUC MTConnect	●	
Others	FANUC OPC UA	⊕	
	Display unit	10.4" color LCD	X
		15" color LCD	X
		15" color LCD with Touch Panel	●
	Part program storage size & Number of registerable programs	640M(256KB)_500 programs	X
		1280M(512KB)_1000 programs	○
		2560M(1MB)_1000 programs	○
		5120M(2MB)_1000 programs	○
		10240M(4MB)_1000 programs	●
		20480M(8MB)_1000 programs	○
		2560M(1MB)_2000 programs	○
		5120M(2MB)_4000 programs	○
10240M(4MB)_4000 programs		○	
20480M(8MB)_4000 programs	○		

\*1) The number of look-ahead blocks may be changed or limited depending on the peripheral device or the configuration of the internal NC system.





\*2) Available Option only with Fanuc i plus iHMI

● Standard ○ Optional X Not applicable ⊕ Available  
Network: FANUC MTConnect and FANUC OPC UA available.

# EZ WORK

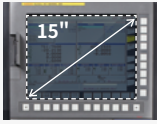
Operator convenience and work efficiency have been improved with adoption of various convenient control functions and ergonomic design.

## Operating console

<p><b>1.</b> <b>15" Color TFT LCD Monitor</b></p> 	<p><b>2.</b> <b>Mono Lever</b></p> 
<p><b>3.</b> <b>Membrane Keyboard</b></p> 	<p><b>4.</b> <b>Portable MPG</b></p> <p><b>LCD Portable MPG Handle</b> <small>OPTION</small></p> 
<p><b>5.</b> <b>Hot Key</b></p> 	<p><b>6.</b> <b>Swiveling Operation Panel</b></p> <p>The operation panel can swivel up to 80° improving user convenience.</p>

## Excellent accessibility

NX 5500 II	A	mm (inch)	815 (32)
	B	mm (inch)	265 (10)
	C	mm (inch)	860 (34)

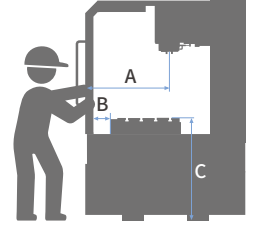

## Convenient absolute feed

The current position of the machine is stored and maintained using battery power. Zero point return is not necessary after a power cycle.

## System condition indicator LED Indoor work light



- Warning lamp**  
Reports abnormal operating condition of the machine
- Work completion indicator**  
Indicates that the work is finished
- In-progress lamp**  
Indicates that the work is being carried out



LED lamp provides higher brightness and longer life with reduced energy consumption.

## Ez work

The EOP package delivers speed and efficiency. This menu-driven innovation not only helps customers reduce setup times, but also simplifies common tasks and procedures, reducing the potential for errors. EOP reduces operating time, protects machinery.

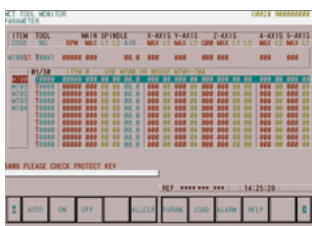

**Tool Load Monitor**  
Function to automatically monitor tool load (Different loads can be set for one tool according to M700 ~ M704)



**M/G-Code List**  
Functional description of M code and G code



**Tool Management**  
Function to manage tool information [Tool information / Tool condition (normal, large diameter, worn / damaged, used for the rst time, manual) / Tool name]

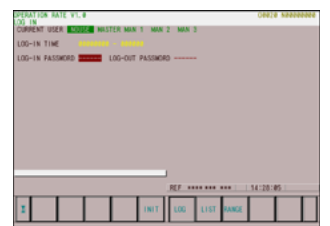

**Operation Rate**  
Machine operation history management function by date based on load



**Adaptive Feed Control**  
Function to control feedrate so that the cutting can be carried out at a constant load (To adapt to the spindle load set up with constant load feedrate control function)

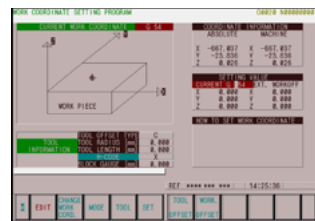

**Work Offset Setting**  
Easy set for work offset setting



**Spindle Warm Up**  
A function that assists spindle warm-up for spindle life when the spindle has not been used for a certain period of time



**ATC Recovery**  
Function to view detailed info with recommended actions and to perform step-by-step operation manually (when an alarm is triggered during an ATC operation)

# CONVENIENT OPERATION

## HEIDENHAIN TNC640

### Superior hardware specifications

The TNC 640 features optimized motion control, short block processing times and special control strategies. Together with its uniform digital design and its integrated digital drive control (including inverters), it enables you to achieve high machining speeds and the best possible contour accuracy.

- 15.6" display
- 21GB Storage memory
- 500 look ahead blocks
- High user convenience with folder structure data management

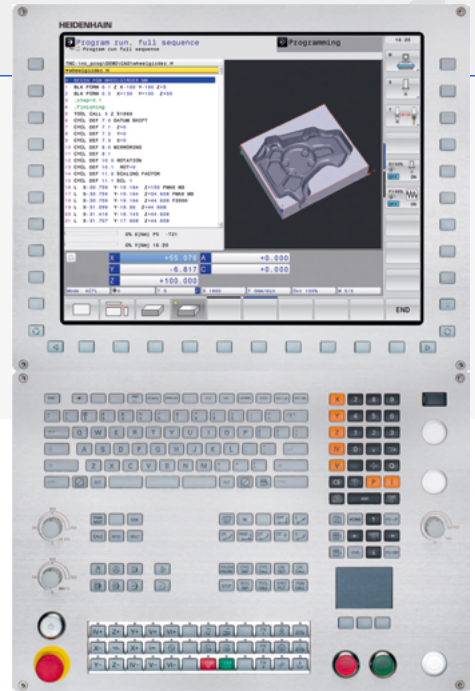

### Conversational convenient function

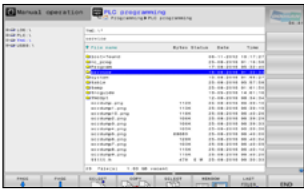

Data are controlled in the folder structure; convenient communication via USB devices



KinematicOpt & KinematicComp **OPTION**  
(Touch probe cycle for automatic measurement)

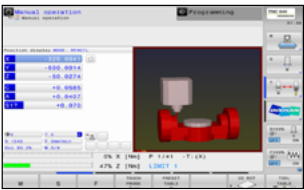

Collision protection system **OPTION**



Adaptive feed control **OPTION**



Various built-in pattern cycles for a wider scope of application (Software standard)

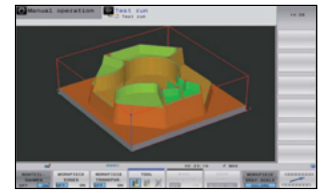

Graphic simulation

## NUMERIC CONTROL SPECIFICATIONS



Item	Specifications	TNC640	
		NX 5500 II	
Controlled axis	Controlled axis	3 (X,Y,Z)	
	Simultaneously controlled axis	4 axis	
Data input/output	USB memory input/output	●	
Interface function	Embedded ethernet	●	
Feed function	Look-ahead	5000 blocks	
Axis compensation	KinematicsOpt	Automatic measurement and optimization of machine kinematics	
Collision monitoring	Dynamic collision monitoring (DCM)	X	
Network	MTConnect	⊕	
Others	Display unit	15.1 inch TFT color flat panel	●
		15.1 inch TFT color with Touch Panel	○
		19 inch TFT color flat panel	○
		19 inch TFT color with Touch Panel	○
	Part program storage size & number of registerable programs	21GB	●
	1.8GB	X	

● Standard ○ Optional X Not applicable ⊕ Available

# POWER | TORQUE

## 20000 r/min

Max. Spindle torque:  
**22 kW** (30 Hp)

Taper  
**ISO #40**

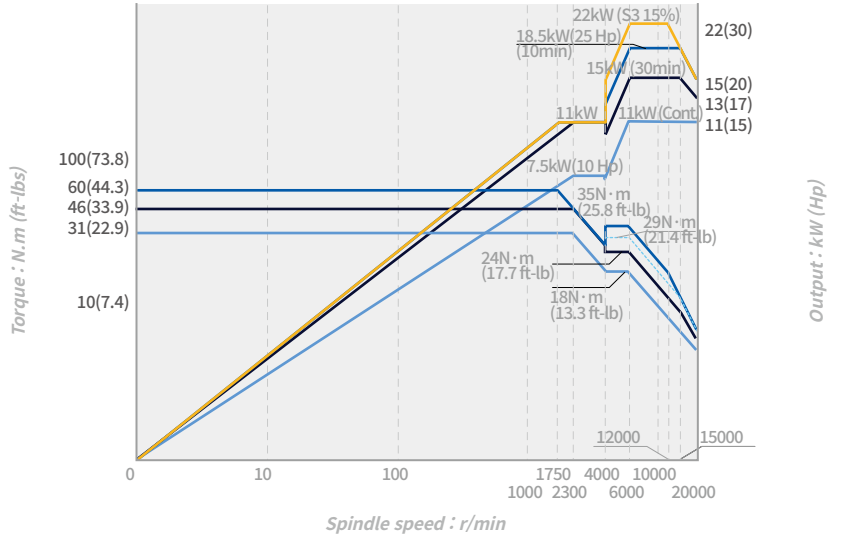

## 30000 r/min

Max. Spindle torque:  
**18.5 kW** (25 Hp)

Taper  
**HSK-F63** OPTION

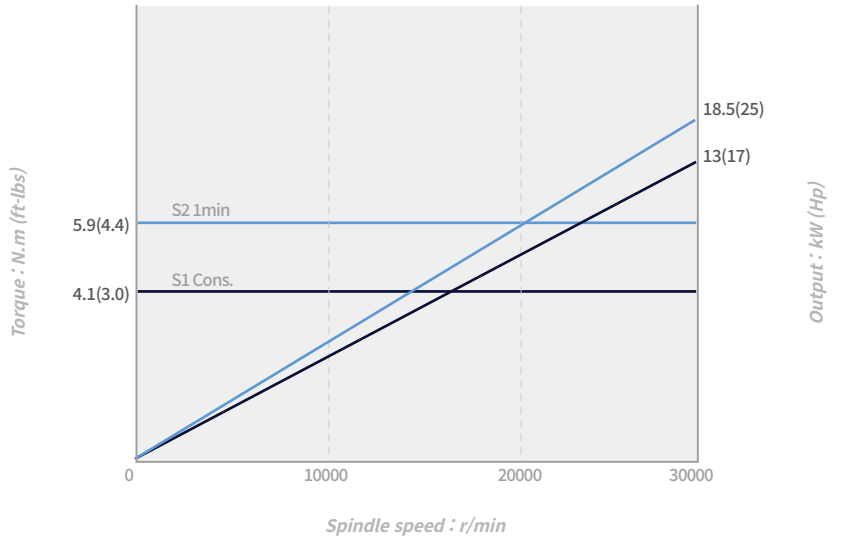

## 40000 r/min

Max. Spindle torque:  
**5.5 kW** (7 Hp)

Taper  
**HSK-E40** OPTION

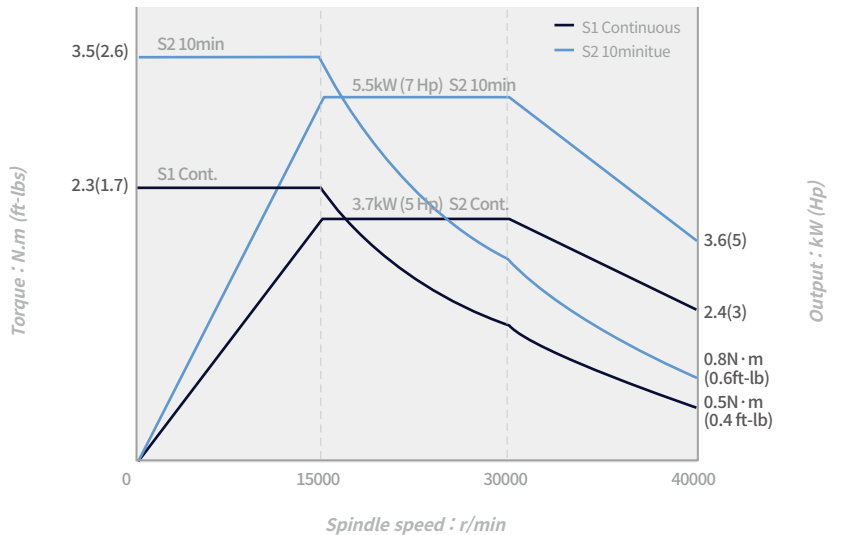

# DIMENSIONS

Units : mm (inch)

TOP

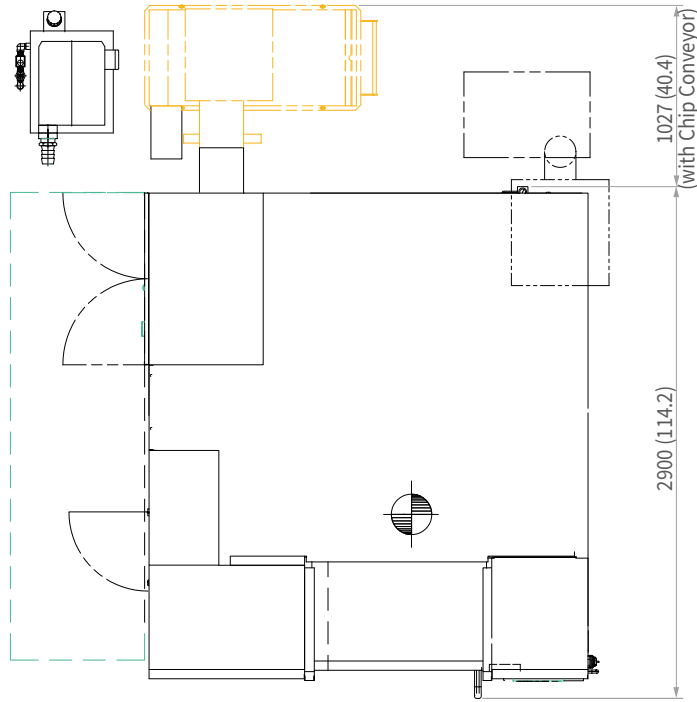

FRONT

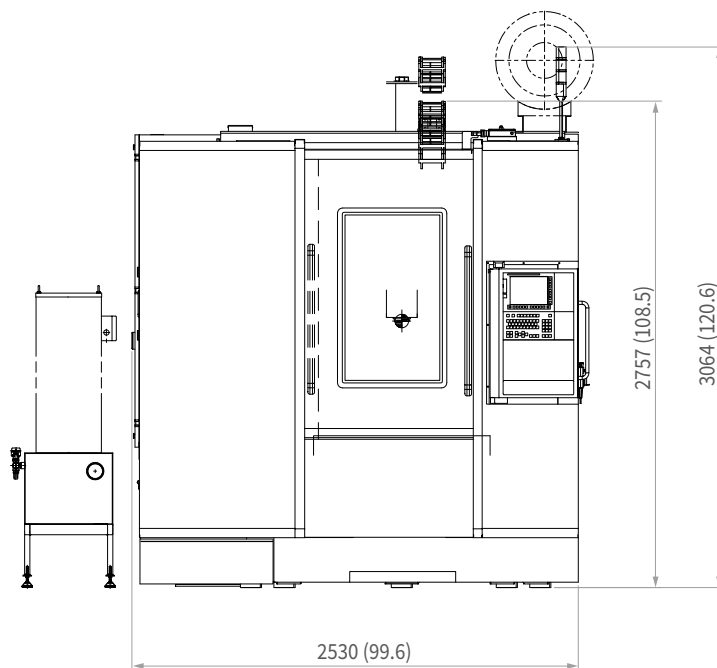

\* Some peripheral equipment can be placed in other areas.

# TABLE | TOOL SHANK

TABLE

Units : mm (inch)

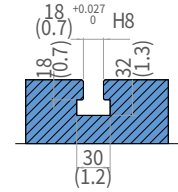
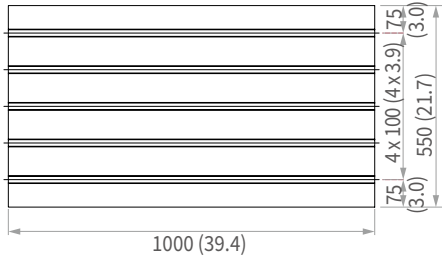

20000 r/min

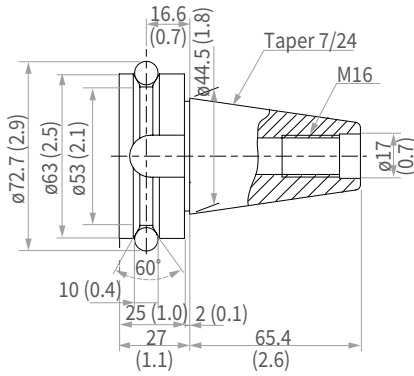

MAS 403 BT40

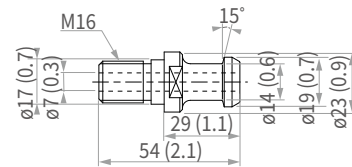

PS-806 (NIKKEN)

20000 r/min **OPTION**

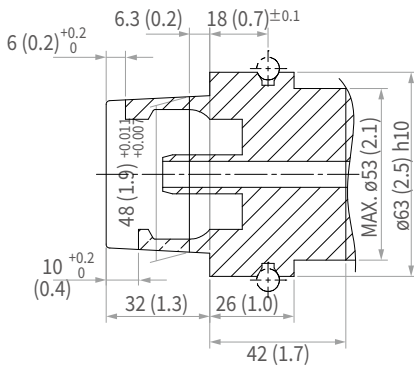

HSK A63

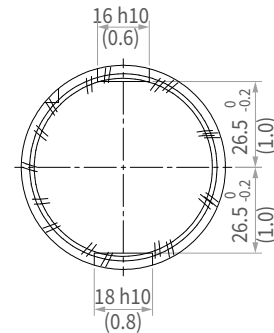

30000 r/min **OPTION**

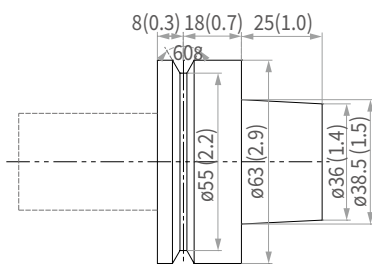

DIN 69893 HSK-F63

40000 r/min **OPTION**

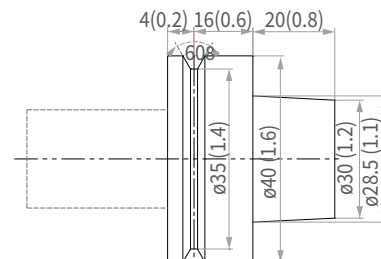

DIN 69893 HSK-E40

# MACHINE SPECIFICATIONS

Item		Unit	NX 5500 II
Travels	X, Y, Z axis	mm (inch)	900 / 550 / 500 (35.4 / 21.7 / 19.7)
	Distance from spindle nose to table top	mm (inch)	150 ~ 650 (5.9 ~ 25.6)
Feedrates	Rapid traverse (X / Y / Z axis)	m/min (ipm)	30 / 30 / 30 (1181.1)
	Cutting feedrate	m/min (ipm)	15 (590.6)
Table	Table size	mm (inch)	1000 x 550 (39.4 x 21.7)
	Table loading capacity	Kg (lb)	700 (1543.2)
Spindle	Max. spindle speed	r/min	20000 {30000, 40000}*
	Spindle motor (10min/cont.)	kW (Hp)	22 / 11 (29.5 / 14.8) {18.5 / 13 (24.8 / 17.4), 5.5 / 3.7 (7.4 / 5.0)}*
	Taper spindle	Taper	ISO #40 7/24 {HSK-F63, HSK-E40}*
	Max. spindle torque (10min)	N.m (ft-lbs)	60 (44.3) {5.9, 3.5 (4.3, 2.6)}*
Automatic Tool Changer	Number of tools	ea	30
	Max. tool diameter	mm (inch)	80 (3.1)
	Max. tool diameter without adjacent tools	mm (inch)	125 (4.9)
	Max. tool length	mm (inch)	220 (8.7)
	Max. tool weight	Kg (lb)	7 (15.4)
	Max. tool moment	N·m (ft-lbs)	7.84 (5.8)
	Tool change time (tool-to-tool)	s	1.6
Power Source	Electric power supply	kVA	46.6 {43, 31}*
Tank Capacity	Coolant tank capacity	L (gal)	230 (60.8)
	Lubrication tank capacity	L (gal)	3.0 (0.8)
Machine Demensions	Length x Width	mm (inch)	2530 x 2900 (99.6 x 114.2)
	Height	mm (inch)	3064 (120.6)
	Weight	Kg (lb)	9000 (19841.3)
NC system		-	Fanuc 31i Plus {HEIDENHAIN}*

# WHY DN SOLUTIONS

The DN Solutions promise, MACHINE GREATNESS, has two important meanings. The first is simple: DN Solutions makes great machines. The second is a challenge to our end-users. With a product line that is this comprehensive, accurate and reliable, we equip our customers to machine greatness. The big question: *Why should you choose DN Solutions over other options?* Here's why...

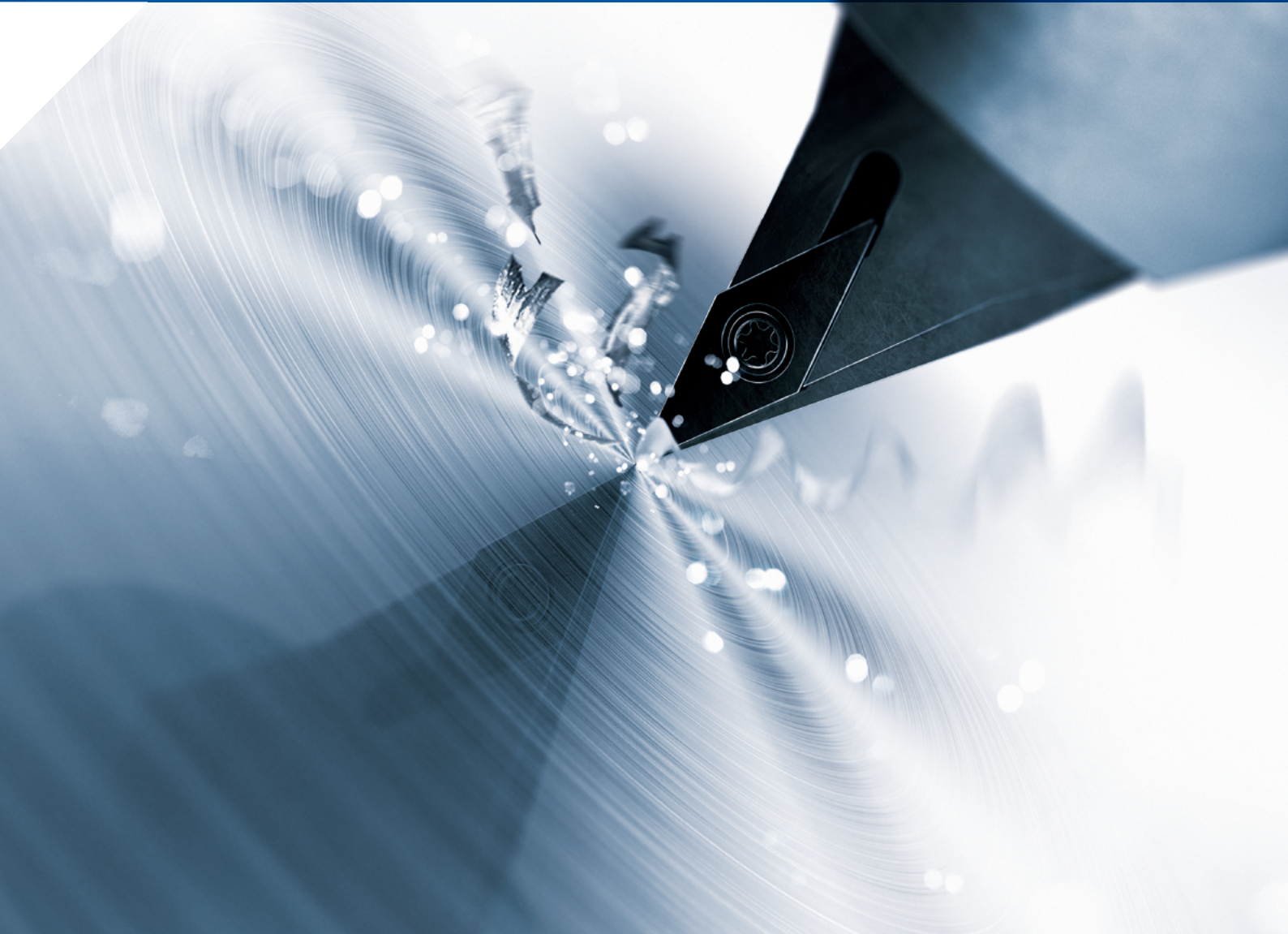

## UNBEATABLE MACHINES

You won't find a more comprehensive range or a better combination of value, performance and reliability anywhere else.

## READILY AVAILABLE - ANYWHERE IN THE WORLD

Machining centres (including 5-axis machines), lathes, multi-tasking turning centres and mill-turn machines, and horizontal borers with best-in-class specifications are all available...ready to install.

## ROBUST PRODUCT LINE

We offer an impressive range of machine models and hundreds of configurations. Whatever your machining needs and requirements, there's a DN Solutions for you.

## EXPERT SERVICE

Our dedicated, experienced and knowledgeable team is totally committed to improving your productivity, growth and success.

# RESPONDING TO CUSTOMERS **ANYTIME, ANYWHERE**

## DN SOLUTIONS GLOBAL NETWORK

**66** COUNTRIES | **140** + SALES NETWORKS | **3** FACTORIES | **6** REGIONAL HQS



## CUSTOMER SUPPORT AND SERVICES

### WE'RE THERE FOR YOU WHENEVER YOU NEED US.

We help our customers operate at maximum efficiency by providing them with a range of tried, tested and trusted services - from pre-sales consultancy to post-sales support.



#### FIELD SERVICES

- On-site service
- Machine installation and testing
- Scheduled preventive maintenance
- Machine repair service



#### PARTS SUPPLY

- Supplying a wide range of original DN Solutions spare parts
- Parts repair service



#### TRAINING

- Programming, machine setup and operation
- Electrical and mechanical maintenance
- Applications engineering



#### TECHNICAL SUPPORT

- Supports machining methods and technology
- Responds to technical queries
- Provides technical consultancy



**Head Office**

19F, 10, Tongil-ro, Jung-gu, Seoul,  
Republic of Korea, 04527

Tel: +82-2-6972-0370  
Fax: +82-2-6972-0400

**DN Solutions America**

360 E State PKWY,  
Schaumburg, IL. 60173,  
United states

Tel: +1-315-265-7500

**DN Solutions Europe**

Emdener Strasse 24, D-41540  
Dormagen, Germany

Tel: +49-2133-5067-100  
Fax: +49-2133-5067-111

**DN Solutions India**

No.82, Jakkuar Village  
Yelahanka Hobil,  
Bangalore-560064

Tel: +91-80-2205-6900  
E-mail: [india@dncompany.com](mailto:india@dncompany.com)

**DN Solutions China**

Room 101,201,301,  
Building 39 Xinzhuan Highway  
No.258 Songjiang District  
China Shanghai (201612)

Tel: +86 21-5445-1155  
Fax: +86 21-6405-1472

**DN Solutions Vietnam**

M.O.R.E building 2F, 40A-40B Ut  
Tich Street, 04 Ward 04,  
District Tan Binh District,  
Ho Chi Minh City, Vietnam  
Tel: +84 28-7304-0163

**DN Solutions Mexico**

Avenida Parque Bicentenario  
#100 Nave M65L3-6,  
Fraccionamiento San Isidro  
Business Park,  
Santa Rosa Jauregui,  
Querétaro, México

E-mail: [efrain.figueroa@dncompany.com](mailto:efrain.figueroa@dncompany.com)

**Sales inquiry**

[sales@dncompany.com](mailto:sales@dncompany.com)